

Enrich Workbook with Projects

Grade 2

 **Harcourt**
SCHOOL PUBLISHERS
Visit *The Learning Site!*
www.harcourtschool.com

HSP Math

Copyright © by Harcourt, Inc.

All rights reserved. No part of this publication may be reproduced or transmitted in any form or by any means, electronic or mechanical, including photocopy, recording, or any information storage and retrieval system, without permission in writing from the publisher.

Permission is hereby granted to individuals using the corresponding student's textbook or kit as the major vehicle for regular classroom instruction to photocopy entire pages from this publication in classroom quantities for instructional use and not for resale. Requests for information on other matters regarding duplication of this work should be addressed to School Permissions and Copyrights, Harcourt, Inc., 6277 Sea Harbor Drive, Orlando, Florida 32887-6777. Fax: 407-345-2418.

HARCOURT and the Harcourt Logo are trademarks of Harcourt, Inc., registered in the United States of America and/or other jurisdictions.

Printed in the United States of America

ISBN 13: 978-0-15-356773-5

ISBN 10: 0-15-356773-2

If you have received these materials as examination copies free of charge, Harcourt School Publishers retains title to the materials and they may not be resold. Resale of examination copies is strictly prohibited and is illegal.

Possession of this publication in print format does not entitle users to convert this publication, or any portion of it, into electronic format.

1 2 3 4 5 6 7 8 9 10 082 16 15 14 13 12 11 10 09 08 07

Contents

ENRICH PROJECTS

Chapter 1	Addition	EP1
Chapter 2	Subtraction.....	EP2
Chapter 3	Making Groups	EP3
Chapter 4	Greater Numbers	EP4
Chapter 5	Making Tens.....	EP5
Chapter 6	Exploring Addition	EP6
Chapter 7	Exploring Subtraction.....	EP7
Chapter 8	2-Digit Subtraction	EP8
Chapter 9	Pictures of the Weather	EP9
Chapter 10	Possible or Impossible	EP10
Chapter 11	Counting Patterns	EP11
Chapter 12	Make the Same Amount.....	EP12
Chapter 13	Time on a Clock	EP13
Chapter 14	Make a Solid Figure	EP14
Chapter 15	Plane Figure Mosaics.....	EP15
Chapter 16	House of Cards.....	EP16
Chapter 17	Measure with Your Shoe.....	EP17
Chapter 18	Heavy or Light?.....	EP18
Chapter 19	Cutting in Half.....	EP19
Chapter 20	Counting by Tens.....	EP20
Chapter 21	Money Amounts	EP21
Chapter 22	Adding Hundreds	EP22
Chapter 23	Subtracting Hundreds	EP23
Chapter 24	Making Equal Groups.....	EP24

ENRICH WORKSHEETS

UNIT 1: NUMBER AND OPERATIONS

Chapter 1: Addition Facts and Strategies

1.1	More Addition Sentences.....	EW1
1.2	A Maze to Count On.....	EW2
1.3	Mystery Number.....	EW3
1.4	A Teen Number Chart.....	EW4
1.5	Clues for Sums	EW5
1.6	Fix It	EW6
1.7	Some Sums.....	EW7
1.8	Problems, Problems.....	EW8

Chapter 2: Subtraction Facts and Strategies

2.1	What is the Difference?.....	EW9
2.2	Hopping Back to 0	EW10
2.3	Making Fact Families	EW11
2.4	Which Number Goes Where?.....	EW12
2.5	Missing Addend Patterns.....	EW13
2.6	Finish the Problem	EW14

Chapter 3: Place Value to 100

3.1	How Many Points?	EW15
3.2	Get Your Pencils Here	EW16
3.3	Least and Greatest	EW17
3.4	Follow the Lines	EW18
3.5	More Riddles.....	EW19
3.6	Match the Models.....	EW20
3.7	Planning a Picnic	EW21

Chapter 4: Number Concepts and Patterns

4.1	Color That Train	EW22
4.2	Digit Arrangements	EW23
4.3	Least to Greatest, Greatest to Least	EW24
4.4	Be a Basketball Detective	EW25
4.5	Even Sums, Odd Sums.....	EW26
4.6	More About Skip-Counting	EW27
4.7	Patterns and Problems.....	EW28
4.8	Two Number Patterns	EW29

UNIT 2: 2-DIGIT ADDITION AND SUBTRACTION

Chapter 5: Explore 2-Digit Addition

5.1	What Number Am I?.....	EW30
5.2	Story Problem Fun.....	EW31
5.3	Write the Addition Problem.....	EW32
5.4	What is the Problem?	EW33
5.5	Find the Errors.....	EW34
5.6	Arrange the Digits	EW35

Chapter 6: 2-Digit Addition

6.1	How Does It Add Up?	EW36
6.2	The Lost Digits.....	EW37
6.3	How Many Could There Be?.....	EW38
6.4	Estimation Challenge.....	EW39
6.5	Mystery Addends.....	EW40
6.6	Missing Points.....	EW41
6.7	Which Toys?	EW42

Chapter 7: Explore 2-Digit Subtraction

- 7.1 How Many Tens?EW43
- 7.2 Subtract to MatchEW44
- 7.3 Match the MatsEW45
- 7.4 Follow the CluesEW46
- 7.5 Balancing AmountsEW47
- 7.6 Subtraction WheelsEW48

Chapter 8: 2-Digit Subtraction

- 8.1 Fill in the BlanksEW49
- 8.2 Two-Step ProblemsEW50
- 8.3 Jumbled NumbersEW51
- 8.4 The Same DifferenceEW52
- 8.5 Add to SubtractEW53
- 8.6 Find the MistakeEW54
- 8.7 Use the MethodEW55
- 8.8 Where to Start?EW56
- 8.9 A Pair of ProblemsEW57

UNIT 3: DATA, PROBABILITY, MONEY, AND TIME

Chapter 9: Data and Graphs

- 9.1 Missing Survey DataEW58
- 9.2 Sunflower GrowthEW59
- 9.3 Summer Bar GraphEW60
- 9.4 Grocery Basket GraphsEW61
- 9.5 Missing KeysEW62
- 9.6 Make a Line PlotEW63
- 9.7 Make a TownEW64

Chapter 10: Probability

- 10.1 Color the SpinnersEW65
- 10.2 Color the CubesEW66
- 10.3 Missing SpinsEW67
- 10.4 Creative SpinnersEW68
- 10.5 PredictionsEW69

Chapter 11: Count Money

- 11.1 Bunches of FlowersEW70
- 11.2 What is the Missing Coin?EW71
- 11.3 Groups of CoinsEW72
- 11.4 Matching ChangeEW73
- 11.5 More Than One WayEW74

Chapter 12: Use Money

- 12.1 Fruit StandEW75
- 12.2 Saving CoinsEW76
- 12.3 Changing AmountsEW77
- 12.4 On the MenuEW78
- 12.5 Make a DollarEW79
- 12.6 Correct ChangeEW80

Chapter 13: Time

- 13.1 Two Hours at the ParkEW81
- 13.2 Time RiddleEW82
- 13.3 Time at the ZooEW83
- 13.4 School DayEW84
- 13.5 Time to EstimateEW85
- 13.6 Busy from A.M. to P.M.EW86
- 13.7 Fair TimeEW87
- 13.8 World TravelerEW88

UNIT 4: GEOMETRY, PATTERNS, AND MEASUREMENT

Chapter 14: Solid Figures

- 14.1 Solid ColorsEW89
- 14.2 Number Cube NetEW90
- 14.3 Solid Figure PuzzleEW91
- 14.4 Solid Figure RiddlesEW92
- 14.5 Take It ApartEW93
- 14.6 Making ModelsEW94

Chapter 15: Plane Figures and Spatial Sense

- 15.1 Match Plane FiguresEW95
- 15.2 Plane Figure PuzzleEW96
- 15.3 Two Ways to Top ItEW97
- 15.4 Building FiguresEW98
- 15.5 Use the CluesEW99
- 15.6 From Start to FinishEW100
- 15.7 Figure HuntEW101
- 15.8 Half and HalfEW102

Chapter 16: Patterns

- 16.1 Patterned ScarvesEW103
- 16.2 Gridding PatternsEW104
- 16.3 Patterned PizzasEW105
- 16.4 Pattern MatchEW106
- 16.5 How Does the Pattern Grow?EW107
- 16.6 Field DayEW108
- 16.7 Coin CollectorsEW109

Chapter 17: Length, Perimeter, and Area

- 17.1 Compare to MeasureEW110
- 17.2 Best EstimateEW111
- 17.3 Lengths of ObjectsEW112
- 17.4 Length Riddles.....EW113
- 17.5 Color the VegetablesEW114
- 17.6 Centi-Meter FeverEW115
- 17.7 Draw ItEW116
- 17.8 Square UnitsEW117

Chapter 18: Weight, Mass, Capacity, and Temperature

- 18.1 Ounces and Pounds.....EW118
- 18.2 Measuring Mass.....EW119
- 18.3 Fruit Punch.....EW120
- 18.4 Capacity SearchEW121
- 18.5 Changing TemperaturesEW122
- 18.6 Measurement SearchEW123

UNIT 5: FRACTIONS AND GREATER NUMBERS

Chapter 19: Fractions

- 19.1 Make a Quilt.....EW124
- 19.2 Pizza PartyEW125
- 19.3 Missing Problems.....EW126
- 19.4 Same AmountsEW127
- 19.5 Whole PizzasEW128
- 19.6 Three Different PartsEW129

Chapter 20: Place Value

- 20.1 Greatest and LeastEW130
- 20.2 Showing Numbers.....EW131
- 20.3 Value CluesEW132
- 20.4 Cross-Number PuzzleEW133
- 20.5 Find the Ways.....EW134
- 20.6 What Coins?.....EW135

Chapter 21: Compare and Order Greater Numbers

- 21.1 More or LessEW136
- 21.2 Greater, Less, or Equal?EW137
- 21.3 The Middle of the Train.....EW138
- 21.4 Hundreds of PointsEW139
- 21.5 Count by Fives, Count by TensEW140

UNIT 6: 3-DIGIT ADDITION AND SUBTRACTION, MULTIPLICATION AND DIVISION

Chapter 22: 3-Digit Addition

- 22.1 Hundreds in Your HeadEW141
- 22.2 Scrambled Digits.....EW142
- 22.3 3-Digit Decisions.....EW143
- 22.4 What Are the Numbers?.....EW144
- 22.5 Use InformationEW145

Chapter 23: 3-Digit Subtraction

- 23.1 How Many Hundreds?EW146
- 23.2 Disappearing Digits.....EW147
- 23.3 Regroup Tens and Hundreds.....EW148
- 23.4 Keeping Track.....EW149
- 23.5 Triple StepsEW150
- 23.6 Estimate to CheckEW151

Chapter 24: Multiplication and Division Concepts

- 24.1 Skip-Counting.....EW152
- 24.2 A Skip-Counting DiscoveryEW153
- 24.3 Make a BIG Array.....EW154
- 24.4 How Many Vertices?EW155
- 24.5 Lunch TimeEW156
- 24.6 Write Your OwnEW157
- 24.7 Are There Any Left?.....EW158
- 24.8 A ParadeEW159
- 24.9 Division PuzzlesEW160

Enrich Projects

Addition

You can show how numbers are added together by drawing pictures.

Decide

- ✓ Talk about things you can draw.
- ✓ How can a drawing show that things are added together?

Do

- ✓ Count how many animals are in each picture. Write the number. Then draw more animals. How many animals are there now?
- ✓ Write the new number.

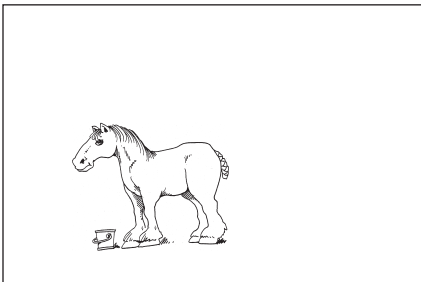

Add
3 more
horses.

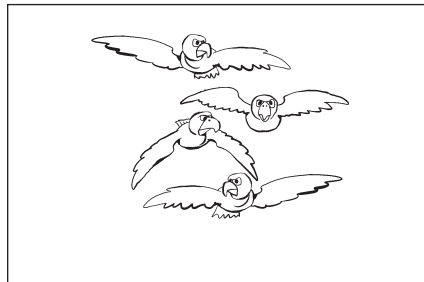

Add
1 more
eagle.

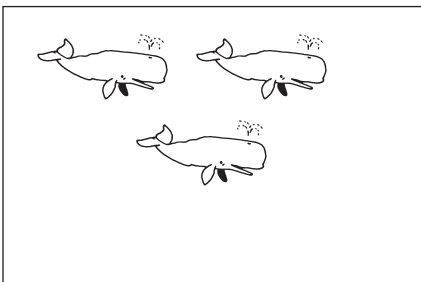

Add
2 more
whales.

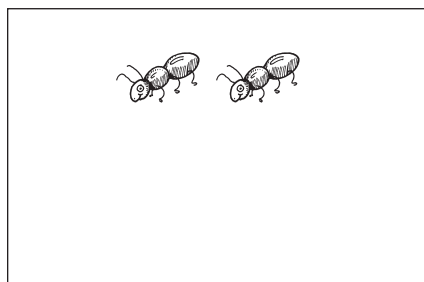

Add
4 more
ants.

Share

- ✓ Draw a group of animals. Exchange pictures with another group. Draw four more animals. How many animals are there in all?

Subtraction

You can draw pictures of objects to help you subtract.

Decide

- ✓ Talk about objects you can draw.
- ✓ How can a drawing show that objects are taken away?

Do

- ✓ Cross out some of the fruits in each picture. Then write the subtraction sentence. Solve.

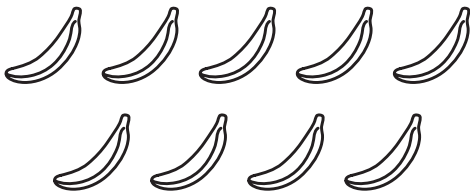

$$\underline{\quad} - \underline{\quad} = \underline{\quad}$$

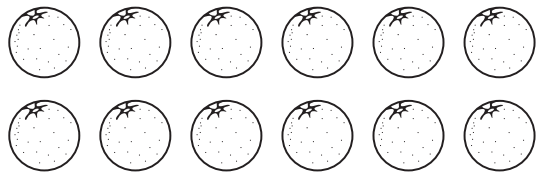

$$\underline{\quad} - \underline{\quad} = \underline{\quad}$$

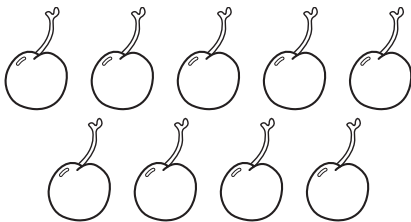

$$\underline{\quad} - \underline{\quad} = \underline{\quad}$$

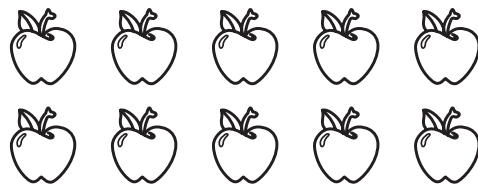

$$\underline{\quad} - \underline{\quad} = \underline{\quad}$$

Share

- ✓ Draw from 5 to 12 toys. Trade drawings with a classmate. Cross out 3 toys. How many toys are left?

Making Groups

We make groups by counting objects. You can place the same number of objects in each group.

Decide

- ✓ Talk about how you can group objects.
- ✓ Talk about equal and unequal groups.

Do

- ✓ Place 6 beans on a piece of paper.
- ✓ Put the beans in two equal groups. Draw a picture to match.
- ✓ How many beans are in each group?
- ✓ Place the beans in three equal groups. Draw a picture to match.
- ✓ How many beans are in each group?
- ✓ Can you place 6 beans in unequal groups. Draw a picture to match.



Share

- ✓ Choose a number from 1 to 10. Draw 3 groups of buttons. Place the same number of buttons in each group. Exchange drawings with someone in your group. Make a new drawing that shows that same number of buttons in unequal groups.

Greater Numbers

Numbers have different values. These values can be shown in different ways.



Decide

- ✓ Talk about the value of a number.
- ✓ How can you tell if one number is greater than another number?
- ✓ How can you show that numbers have different values?

Do

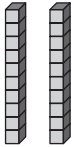
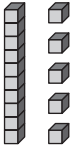
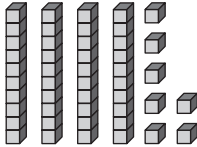
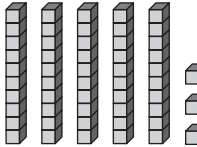
- ✓ Write how many tens and ones.
- ✓ Circle the greater number of each pair.

			
_____ tens _____ ones	_____ ten _____ ones	_____ tens _____ ones	_____ tens _____ ones

- ✓ Use   and Workmat 3 to show each number. Circle the greater number of each pair.

43

28

45

18

Share

- ✓ Write five pairs of numbers on a piece of paper. Exchange lists with another group. Circle the greater number of each pair.

Making Tens

You can show numbers by making groups of ten. Count the number by ones. Each time you make ten, begin a new group.

Decide

- ✓ How can you show groups of ten?
- ✓ Talk about what happens when you complete a group of ten.

Do

- ✓ Color one square for each number as you count. Write the number of tens. Then write the number of ones.

19

_____ tens _____ ones

- ✓ On a piece of paper, write a number from 25 to 40. Exchange papers with someone in your group.

11

_____ tens _____ ones

- ✓ Show the number by drawing groups of ten. Write the number of tens. Then write the number of ones.

23

_____ tens _____ ones

Share

- ✓ Choose a number from 50 to 100. Work with your partner to show this number by drawing groups of ten.

Exploring Addition

Grouping is important in addition. When you have 10 ones, you can regroup. The 10 ones become 1 ten.

Decide

- ✓ When do you have to regroup in the ones column?
- ✓ How is regrouping used in 2-digit addition?

Do

- ✓ Use  and Workmat 3 to solve this addition problem.

In a ball game, one team scores 56 points. The other team scores 28 points. How many points are scored in all?

- ✓ Write the sum.
- ✓ Write a story problem that uses 2-digit addition with addends that are less than 50.
- ✓ Draw a picture to match.

Share

- ✓ Exchange story problems with a classmate.
- ✓ Use  and Workmat 3 to solve.

Exploring Subtraction

When you subtract, you take things away. You can show this by making a model, drawing a picture, or writing a number sentence.

Decide

- ✓ How can you model subtraction with ?
- ✓ How can you show subtraction with a drawing?
- ✓ How do you write a subtraction sentence?

Do

- ✓ Use  to model and solve.

There are 16 books on a shelf. 9 books are taken off the shelf. How many books are left?

- ✓ Draw a picture to solve. Cross out the objects you subtract.

There are 12 apples on a tree. 3 apples fall off the tree. How many apples are left? 3 more apples fall off the tree. Now how many apples are left?

- ✓ Write a number sentence to solve.

There are 18 birds on a bench. 7 birds fly away. How many birds are left? 8 more birds fly away. Now how many birds are left?

Share

- ✓ Write a subtraction story problem. Exchange with another group and solve.

2-Digit Subtraction

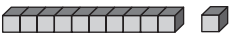
In 2-digit subtraction, you may need to regroup. You can use  to show this change. To regroup, change 1 ten into 10 ones.

Decide

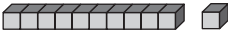
- ✓ Talk about how you can use  to help you solve subtraction problems.
- ✓ When do you regroup in subtraction?

Do

- ✓ Use  to model and solve this 2-digit subtraction problem.

A bracelet has 76 beads. Another bracelet has 59 beads. How much longer is one bracelet than the other?

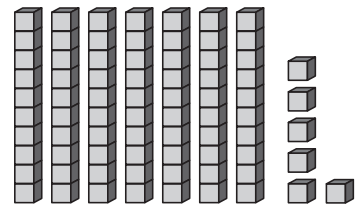

- ✓ Use addition to check your answer.

Share

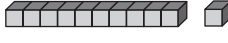
- ✓ Write a 2-digit subtraction problem. Exchange papers with someone in your group. Use  to solve. Use addition to check your answer.

	tens	ones
	<input type="text"/>	<input type="text"/>
	7	6
—	5	9

Pictures of the Weather

We look at weather reports to find out what the weather will be like. Some weather reports use pictures. What do the pictures show? Some pictures show a bright sun. Some pictures show a sun covered by clouds. Other pictures show snow. Show the weather using pictures.

Decide

- ✓ What types of weather will you show?
- ✓ What will you draw to stand for each type of weather?
- ✓ When should you use the same picture again?

Do

- ✓ Make a table like the one shown here.

Monday Tuesday Wednesday Thursday Friday

--	--	--	--	--

- ✓ Predict what the weather will be like for each day.
- ✓ Make a drawing that shows your prediction for each day.
- ✓ Make a key that shows what each picture stands for.

Share

- ✓ Share your weather reports with your group. Did everyone show the same type of weather? What pictures were used to show weather?

Possible or Impossible



The sections on a spinner will show what is possible or impossible to spin.

Decide

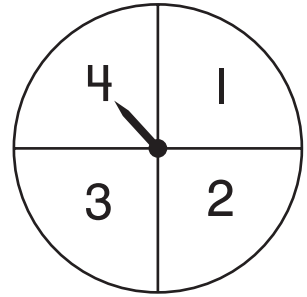
- ✓ What will your spinner have to show to make a spin possible or impossible? How many sections will it have?



Do

- ✓ Get patterns of spinners from your teacher. Choose a pattern or make your own. Cut it out. Use  and  to complete your spinner.
- ✓ Choose one or more of the following statements.
 - It is possible to spin an even number.
 - It is impossible to spin an even number.
 - It is possible to spin a figure with four or more sides.
 - It is impossible to spin a hexagon.
- ✓ Design your spinner to make the statements true.

Share

- ✓ Share your spinners. Discuss what makes each statement true. Write more true statements.
- ✓ Write rules for games to play using your new spinners.

Counting Patterns

When you count on by tens, fives, and ones, you are using patterns. A hundred chart can help you see these patterns.

Decide

- ✓ What happens to a number when you count on by tens? by fives? by ones?

Do

- ✓ Find the number you start with on the hundred chart. Count on by tens, fives, and ones.
- ✓ Complete the table.

1	2	3	4	5	6	7	8	9	10
11	12	13	14	15	16	17	18	19	20
21	22	23	24	25	26	27	28	29	30
31	32	33	34	35	36	37	38	39	40
41	42	43	44	45	46	47	48	49	50
51	52	53	54	55	56	57	58	59	60
61	62	63	64	65	66	67	68	69	70
71	72	73	74	75	76	77	78	79	80
81	82	83	84	85	86	87	88	89	90
91	92	93	94	95	96	97	98	99	100

Start at	Count on by tens.	Count on by fives.	Count on by ones.	End at
5	____, ____	____, ____, ____	____, ____	_____
10	____, ____, ____	_____	____, ____, ____	_____
15	____, ____, ____	_____	_____	_____
20	_____	____, ____, ____	____, ____, ____, ____, ____	_____
25	____, ____, ____	____, ____	____, ____	_____

Share

- ✓ Discuss the patterns you see when you count on by tens, by fives, and by ones.
- ✓ How are these patterns like counting collections of dimes, nickels, and pennies?

Make the Same Amount

Coins have different values. A quarter has a value of 25¢ . A dime has a value of 10¢ . A nickel has a value of 5¢ . You can mix coins to get the same amount.

Decide

- ✓ Talk about the value of different coins.
- ✓ How can the same amount be shown with different combinations of coins?

Do

- ✓ This table shows some ways you can make 99¢ . Use coins to help you complete the table.

Quarters	Dimes	Nickels	Pennies	Total Value
2	4	0	_____	99¢
0	_____	0	9	99¢
0	5	_____	9	99¢
_____	6	2	4	99¢

Share

- ✓ Draw a table like the one above. Fill in 27¢ for each total value.
- ✓ Use coins to show 4 different ways to make 27¢ .
- ✓ Compare your table with the others in your group. How many ways are the same as yours? How many ways are different?

Time on a Clock

There are different types of clocks. Some clocks show the time in numbers. Other clocks show the time with an hour hand and a minute hand.

Decide

- ✓ Talk about different types of clocks. How are they the same? How are they different?
- ✓ What types of clocks are in your classroom?

Do

- ✓ Look at each pair of clocks. One clock shows the time. The other clock is blank. Show the same time on the blank clock.

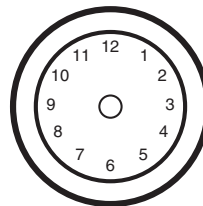
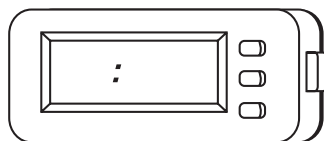
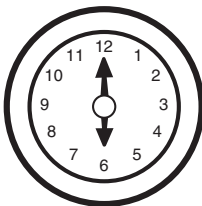
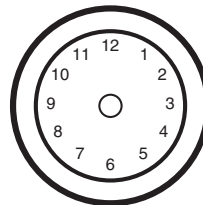
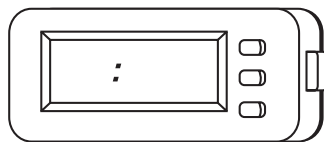
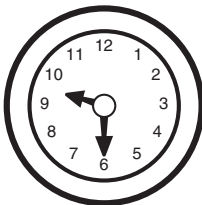
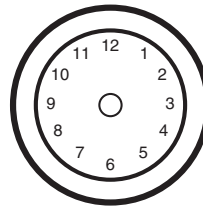
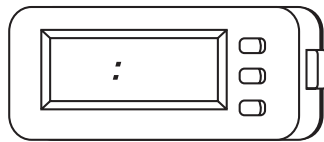
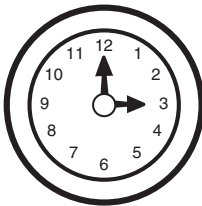

Share

- ✓ Draw a clock that shows a time to the hour or half hour. Exchange drawings with a classmate. Now draw a different kind of clock that shows the same time.

Make a Solid Figure

Look around your classroom. Which solid figures do you see? Work with your group to identify different solid figures in your classroom.

Decide

- ✓ Make a list of the solid figures you see.
- ✓ Which solid figures do you see a lot of? Which solid figures do you see only a few of?
- ✓ Can you fold a sheet of paper into the shape of a box?

Do

- ✓ Get a pattern from your teacher. Use scissors to cut out the pattern.
- ✓ Make a box by folding along the dotted lines.
- ✓ Use tape to hold the figure together.
- ✓ How many sides does your box have?
- ✓ Make a model of a different solid figure from a sheet of paper.

Share

- ✓ Compare your new solid figure with the solid figures made by other children in your group. Talk about how they are different and how they are the same.

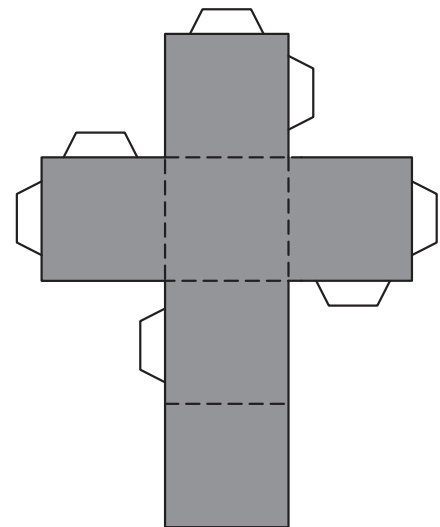
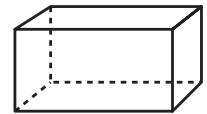
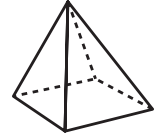
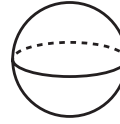
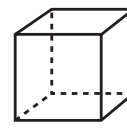

Plane Figure Mosaics

A mosaic is a design that can be made by putting figures together. In this project, you will make mosaics using plane figures.

Decide

- ✓ What kind of design will you make?

Do

- ✓ Fold a sheet of paper in half.
- ✓ Get pages of plane figures from your teacher. Cut them out.
- ✓ Glue the figures to one half of the paper to make a mosaic design. Color the figures.
- ✓ Count how many figures you used in all. Count the total number of sides on each figure in your mosaic.

Share

- ✓ Discuss and compare how many figures you and your group used. Discuss and compare the total number of sides there are in your mosaics.
- ✓ Exchange papers with someone in your group.
- ✓ Cut out that same number and type of plane figures.
- ✓ Glue these figures to the other half of the paper to show a different plane figure mosaic. Color the figures.

House of Cards

What is your house made of? Is it made of wood? Is it made of bricks? In this project, you will make a house of cards.

Decide

- ✓ Talk about how you might do this.
- ✓ Talk about how many floors you think it will have.

Do

- ✓ Work with a partner.
- ✓ Make a 2-card support by leaning two cards against each other. Tape the top edges together.
- ✓ Tape the bottom of the edge of the cards to the desk.
- ✓ Make another 2-card support.
- ✓ Place a card across the tops of the cards.
- ✓ Extend the row by repeating this design.
- ✓ Add another floor to the house. How high will you be able to make this house? Explain.

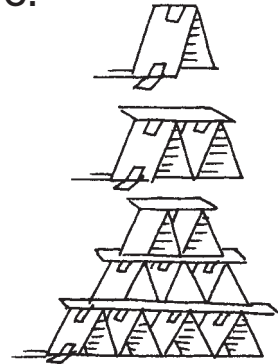

Share

- ✓ Work with your group to make other structures with cards. Discuss the patterns you use. Which design uses the most cards?

Measure with Your Shoe

A ruler is a measuring tool. It can tell you how long an object is. You can use things other than a ruler to measure. You can even use your shoe.

Decide

- ✓ How can you tell how long something is?
- ✓ Talk with your group about how a ruler is used.
- ✓ Can other objects be used as a measuring tool?

Do

- ✓ Work with a partner.
- ✓ Put one heel against the wall. Place the other foot in front, touching the heel to the toe.
- ✓ Walk heel-to-toe across the room in a straight line, while your partner counts each step.
- ✓ How many steps did it take to cross the room?
- ✓ Exchange roles.
- ✓ Did both of you cross the room in the same number of steps? Discuss.

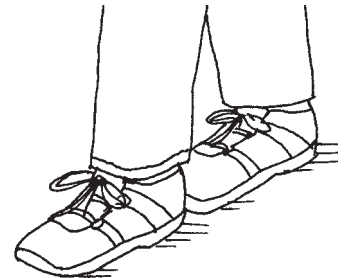

Share

- ✓ Have each person draw and cut out an outline of his or her shoes. Exchange outlines with someone else. Use them to measure the distance heel-to-toe across the room. Did you cross the room in the same number of steps as before? Discuss your results.

Heavy or Light?

Suppose you pick up two bags of marbles. Without looking inside the bags, can you tell which bag has more marbles?

Decide

- ✓ What can you learn by picking up an object?
- ✓ Talk about tools that we use to find out if something is heavy or light.

Do

- ✓ Work with a partner.
- ✓ Have your partner close his or her eyes. Then place 20 marbles in a small paper bag. Place 2 marbles in another paper bag.
- ✓ Give both bags to your partner to hold.
- ✓ Without shaking the bags, ask which bag has more marbles.
- ✓ Exchange roles.

Share

- ✓ Put two crayons in one bag. Put 20 crayons in another bag. Close the bags. Exchange bags with another group. Ask them to choose which bag has more crayons.

Cutting in Half

Some sandwiches are big, so we cut them in half. The sandwich halves are smaller, so they are easier to hold.

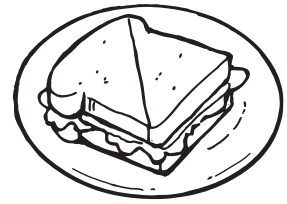

Decide

- ✓ Talk about cutting something in half.
- ✓ What happens to an object when it is cut in half?
- ✓ Can you cut the halves in half again? Explain.

Do

- ✓ Work with a partner. Fold a sheet of paper in half. Open the paper. Cut along the fold line.
- ✓ What happens to the paper when you cut it in half? How many parts do you have now? Describe them.
- ✓ Fold each of the smaller parts in half. Cut each of the parts along the fold line.
- ✓ What happens as you cut the pieces in half? Describe the new parts.
- ✓ How many parts do you have in all?
- ✓ Can you arrange these smaller parts to form the whole piece of paper? Explain.



Share

- ✓ Cut a paper circle in half. Cut each half circle in half. Exchange these four parts with another group. Place the parts back together to look like a whole circle. Try this with other plane figures.

Counting by Tens

At a sports event or concert the seats are usually placed in sections. When you know your section, you can find your seat quickly.

Decide

- ✓ Talk about how seats are placed into sections.
- ✓ How can you find which seat is yours?

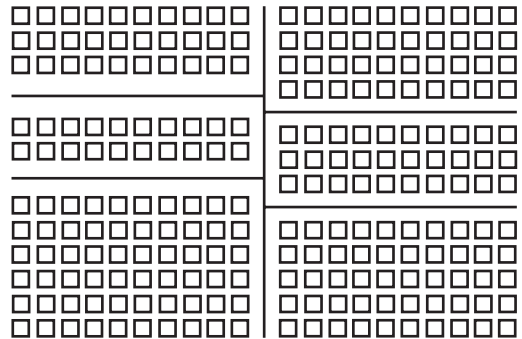

Do

- ✓ The drawing shows rows of 10 seats. The rows are placed into 6 sections.
- ✓ Use a red crayon to circle the section with 50 seats.
- ✓ Use a blue crayon to circle the two sections that have the same number of seats.
- ✓ Use a green crayon to circle the largest section of seats. How many seats are in this section?
- ✓ Use a yellow crayon to circle the section with 40 seats.
- ✓ How many seats are in all 6 sections?

Share

- ✓ Make a drawing that shows 500 seats in a theater. Place the seats in different sections. Keep 10 seats in a row. Exchange your drawing with another classmate. Count by tens and write down the number of seats in each section.

Money Amounts

Coins have different values. How would you find the total value of a collection of coins?

Decide

- ✓ Talk about the value of different coins.
- ✓ What is the best way to find the total value of a collection of coins?

Do

- ✓ Write the value for each group of coins.
- ✓ Circle two groups with the same value.



- ✓ Cross out the group of coins with the greatest value.

Share

- ✓ Work with a partner. Use play coins. Put 10 dimes, 10 nickels, and 10 pennies into a container. Each person should grab a handful of coins. Find and compare your total values.

Adding Hundreds

Different addends can have the same sum. For example, adding 100 and 300 makes a sum of 400. Adding 200 and 200 also makes a sum of 400.

Decide

- ✓ Talk about different combinations of addends that when added will have the same sum.

Do

- ✓ Work with a partner.
- ✓ Write each of the following numbers on a different index card to make two sets: 100, 200, 300, 400, and 500.
- ✓ Complete the table with combinations of addends that make the same sum.
- ✓ Use your cards to help you choose combinations.

sum	addend	addend
600		
700		
800		
900		

Share

- ✓ Share your tables with another group. Discuss how many different combinations there are for each sum.

Subtracting Hundreds

Subtract 3 from 5. The difference is 2. This problem has digits in the ones place. Suppose these same digits were in the hundreds place. How can you subtract?

Decide

- ✓ Talk about how you subtract numbers.

Do

- ✓ Work with a partner. Cut a sheet of blue construction paper into four strips of equal size.
- ✓ Write one of the following numbers on each of the blue paper strips: 600, 700, 800, and 900.
- ✓ Cut a sheet of red construction paper into four strips of equal size.
- ✓ Write one of the following numbers on each of the red paper strips: 100, 200, 300, and 400.
- ✓ Close your eyes and take a blue strip and a red strip.
- ✓ Subtract the number on the red strip from the number on the blue strip. Write the difference.
- ✓ Pick three more combinations of strips. Find the difference in each pair.

Share

- ✓ Compare differences with another group.

Making Equal Groups



Objects can stand alone. You can also place them with other objects to form a group.

Decide

- ✓ Talk about how to place objects in groups.

Do

- ✓ Work with a partner.
- ✓ Draw three circles on a sheet of paper.
- ✓ Place one paper clip in each of the three circles. Fill in each row on the table that describes these three groups.

Groups	Number of Groups	Number of Clips in Each Group	Total Number of Clips
			
			
			

- ✓ Make a new table. Use the same groups of paper clips.
- ✓ Add three more paper clips to each circle.
- ✓ Complete the table. Compare your tables.



Share

- ✓ Work with another group. Draw 6 circles. Compare groups of 1, 2 and 3 paper clips.

Enrich Worksheets

More Addition Sentences

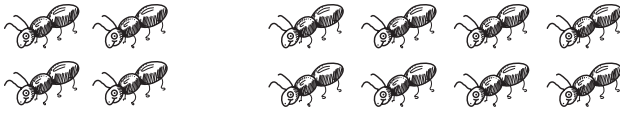
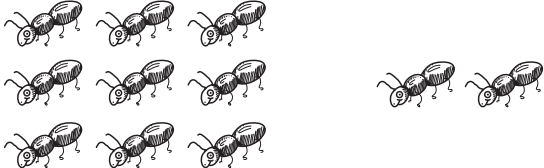
Match the addition sentence to the picture. Fill in the missing numbers. Draw a line to show each match.

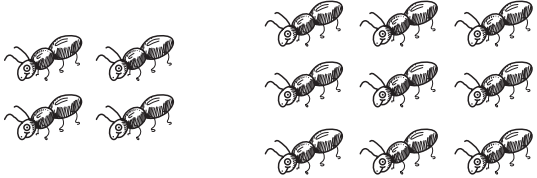
<p>1.</p> 	$5 + \underline{3} = \underline{8}$
<p>2.</p> 	$\underline{\quad} + 7 = 13$
<p>3.</p> 	$4 + \underline{\quad} = \underline{\quad}$
<p>4.</p> 	$\underline{\quad} + \underline{\quad} = 11$
<p>5.</p> 	$\underline{\quad} + 9 = \underline{\quad}$

WRITE Math

Use Exercise 5. Write a story problem to show how you add to join groups.

A Maze to Count On

Count on to find the sum. Start with the greater number.

From START to FINISH, find and color a path in which all of the sums are even. You may move up, down, and across, but not diagonally.

START	$2 + 6 = 8$	$7 + 3 =$	$6 + 2 =$
$6 + 2 =$	$5 + 2 =$	$3 + 6 =$	$1 + 7 =$
$8 + 1 =$	$9 + 1 =$	$2 + 8 =$	$3 + 5 =$
$5 + 3 =$	$8 + 2 =$	$10 + 1 =$	$1 + 7 =$
$1 + 5 =$	$4 + 3 =$	$9 + 3 =$	$6 + 1 =$
$2 + 4 =$	$3 + 7 =$	$2 + 10 =$	FINISH



Use the maze. Explain what happens when you start with an odd number and count on 1, 2, or 3.

Mystery Number

Add to find each sum. Color the boxes that show doubles facts or doubles-plus-one facts to discover the mystery number. Then answer the questions below.

$\begin{array}{r} 6 \\ + 6 \\ \hline \end{array}$	$\begin{array}{r} 3 \\ + 8 \\ \hline \end{array}$	$\begin{array}{r} 5 \\ + 4 \\ \hline \end{array}$	$\begin{array}{r} 7 \\ + 8 \\ \hline \end{array}$	$\begin{array}{r} 8 \\ + 9 \\ \hline \end{array}$
$\begin{array}{r} 7 \\ + 6 \\ \hline \end{array}$	$\begin{array}{r} 4 \\ + 1 \\ \hline \end{array}$	$\begin{array}{r} 9 \\ + 8 \\ \hline \end{array}$	$\begin{array}{r} 2 \\ + 7 \\ \hline \end{array}$	$\begin{array}{r} 7 \\ + 7 \\ \hline \end{array}$
$\begin{array}{r} 3 \\ + 3 \\ \hline \end{array}$	$\begin{array}{r} 2 \\ + 9 \\ \hline \end{array}$	$\begin{array}{r} 8 \\ + 8 \\ \hline \end{array}$	$\begin{array}{r} 8 \\ + 7 \\ \hline \end{array}$	$\begin{array}{r} 4 \\ + 3 \\ \hline \end{array}$
$\begin{array}{r} 4 \\ + 5 \\ \hline \end{array}$	$\begin{array}{r} 7 \\ + 3 \\ \hline \end{array}$	$\begin{array}{r} 5 \\ + 6 \\ \hline \end{array}$	$\begin{array}{r} 1 \\ + 9 \\ \hline \end{array}$	$\begin{array}{r} 4 \\ + 4 \\ \hline \end{array}$
$\begin{array}{r} 6 \\ + 7 \\ \hline \end{array}$	$\begin{array}{r} 5 \\ + 1 \\ \hline \end{array}$	$\begin{array}{r} 5 \\ + 5 \\ \hline \end{array}$	$\begin{array}{r} 3 \\ + 4 \\ \hline \end{array}$	$\begin{array}{r} 6 \\ + 5 \\ \hline \end{array}$

What is the mystery number? _____

What doubles fact has this number as the sum? _____ + _____ = _____

WRITE Math Is there also a doubles-plus-one fact that has this mystery number as the sum? Explain.

A Teen Number Chart

Use a ten frame and the make-a-ten strategy. Write as many problems as you can to equal each teen number in the chart. Each addend must be less than 10.

13	14	15	16	17	18
$7 + 6$	+	+	+	+	+
$6 + 7$	+	+	+	+	
+	+	+	+		
+	+	+			
+	+				
+					



Stretch Your Thinking Design a number chart for the numbers 11 and 12 like the chart above.

Decide how many squares you will need in your chart. Ask a classmate to complete it.

HINT: Follow the pattern shown in this chart.

Clues for Sums

Each clue tells about a rule or pattern that can be used to find sums. You can use more than one clue for each addition sentence. Write the letter of the clue below each addition sentence that it tells about.

$8 + 9 = \underline{17}$  _____	$9 + 9 = \underline{\quad}$ _____	$8 + 7 = \underline{\quad}$ _____	$0 + 6 = \underline{\quad}$ _____
$7 + 7 = \underline{\quad}$ _____	$7 + 8 = \underline{\quad}$ _____	$6 + 0 = \underline{\quad}$ _____	$5 + 4 = \underline{\quad}$ _____

- A. One addend is zero in this number sentence. The other addend is the same as the sum.
- B. Look for a pair of number sentences where the sums are the same, the addends are the same, but the order of the addends is different.
- C. To find the sum for this number sentence, find the doubles fact first and then add one.
- D. Both addends are the same number.



Write a clue for the fact $4 + 7 = 11$.

Fix It

Roger completed the tables below, but he made one mistake in each table. Cross out each mistake. Write the correct number next to each cross out.

1. Rule: Add 6.

In	Out
1	7
2	8
3	9
4	11

2. Rule: Add 4.

In	Out
2	6
4	7
6	10
8	12

3. Rule: Add 9.

In	Out
1	10
4	13
7	17
10	19

4. Rule: Add 8.

In	Out
3	11
5	13
6	16
9	17

5. Rule: Add 7.

In	Out
1	8
5	12
6	12
7	14

6. Rule: Add 5.

In	Out
3	8
5	10
7	13
9	14



The rule is Add 3. Roger puts a number in and gets 8 out. What number does he put in? Explain.

Some Sums

Look at the numbers in each 9-square grid. The box at the end of each row is the sum of the 3 numbers in that row. The box at the end of each column is the sum of the 3 numbers in that column. Add to solve. Write the missing numbers.

1.

2	1	6	9
5		4	
3	6	3	12
10		13	

2.

5		5	15
	3	4	8
4		2	11
10	13		

3.

	3	7	
3	7		11
	3	2	11
12			

4.

8			11
3	5	5	
	5	2	
11			



What do you notice about Exercise 4?

Problems, Problems

Draw a line to connect each word problem to the number sentence that goes with it. Then find each sum to solve.

1. Sari sees 6 caterpillars. Ann sees 3 more caterpillars than Sari. How many caterpillars do the girls see in all?

$$\begin{array}{r} 6 \\ + 5 \\ \hline \end{array}$$

2. Sari sees 6 caterpillars. Ann sees 1 fewer caterpillar than Sari. How many caterpillars do the girls see in all?

$$\begin{array}{r} 6 \\ + 9 \\ \hline \end{array}$$

3. Sari sees 6 caterpillars. Ann sees the same number of caterpillars as Sari. How many caterpillars do the girls see in all?

$$\begin{array}{r} 6 \\ + 3 \\ \hline \end{array}$$

4. Sari sees 6 caterpillars. Ann sees half as many caterpillars as Sari. How many caterpillars do the girls see in all?

$$\begin{array}{r} 6 \\ + 7 \\ \hline \end{array}$$

5. Sari sees 6 caterpillars. Ann sees 5 fewer caterpillars than Sari. How many caterpillars do the girls see in all?

$$\begin{array}{r} 6 \\ + 6 \\ \hline \end{array}$$

6. Sari sees 6 caterpillars. Ann sees 1 more caterpillar than Sari. How many caterpillars do the girls see in all?

$$\begin{array}{r} 6 \\ + 1 \\ \hline \end{array}$$



Explain how drawing a picture could help when solving these problems.

What is the Difference?

Each box has four subtraction sentences.

Two go across. The other two go down.

Fill in the missing numbers so each subtraction sentence is correct.

1.

7	-	2	=	5
-				-
⋮				3
=				=
6	-		=	2

2.

9	-		=	6
-				-
7				
=				=
	-	1	=	1

3.

8	-	3	=	
-				-
1				
=				=
	-		=	4

4.

	-	2	=	
-				-
1				3
=				=
	-	4	=	1

WRITE Math

Choose a subtraction fact from Exercise 4.

Write a subtract to compare problem. Draw a picture.

Hopping Back to 0

The frog starts at 12 on the number line.

It is hopping back to 0.

It must take 7 hops to get back to 0.

The frog can jump back 1, 2, or 3 on each hop.

Complete the subtraction sentences to show a way the frog can do this. Use the number line to help.

There is more than one way to solve.



	The frog starts at	—	It jumps back	=	It lands on
1.	12	—	3	=	9
2.	9	—		=	
3.		—		=	
4.		—		=	
5.		—		=	
6.		—		=	
7.		—		=	0



Stretch Your Thinking What if the frog started at 6 instead of 12? How would that change the problem?

Making Fact Families

Each box has four numbers.

Three of the numbers can make a fact family.

Circle the numbers that belong in the fact family.

Cross out the number that does **not** belong in the fact family.

Then write the facts of the fact family.

1. 2 , 7 , 15 , 8	$\underline{7} + \underline{8} = \underline{15}$ $\underline{\quad} + \underline{\quad} = \underline{\quad}$	$\underline{\quad} - \underline{\quad} = \underline{\quad}$ $\underline{\quad} - \underline{\quad} = \underline{\quad}$
2. 3, 13, 8, 11	$\underline{\quad} + \underline{\quad} = \underline{\quad}$ $\underline{\quad} + \underline{\quad} = \underline{\quad}$	$\underline{\quad} - \underline{\quad} = \underline{\quad}$ $\underline{\quad} - \underline{\quad} = \underline{\quad}$
3. 17, 8, 7, 9	$\underline{\quad} + \underline{\quad} = \underline{\quad}$ $\underline{\quad} + \underline{\quad} = \underline{\quad}$	$\underline{\quad} - \underline{\quad} = \underline{\quad}$ $\underline{\quad} - \underline{\quad} = \underline{\quad}$
4. 5, 6, 9, 15	$\underline{\quad} + \underline{\quad} = \underline{\quad}$ $\underline{\quad} + \underline{\quad} = \underline{\quad}$	$\underline{\quad} - \underline{\quad} = \underline{\quad}$ $\underline{\quad} - \underline{\quad} = \underline{\quad}$



Stretch Your Thinking Use 5, 8, 3, and 13.

Write a fact family using three of these numbers.

Then write another fact family using a different group of three of these numbers.

Which Number Goes Where?

Five children are going to run in a race. Each child wears a number on his or her shirt. The numbers are 5, 6, 7, 8, and 9. Each child has a different number.

Use the clues to decide which child wears which number.

Use related addition facts to help you.

Write each child's number on his or her shirt.

1. When you subtract Andre's number from 11, you get 4.
2. When you subtract Bill's number from 11, you get 2.
3. When you subtract Erin's number from 11, you get Candi's number.
4. When you subtract Dave's number from 17, you get Bill's number.
5. Candi's number is less than Erin's number.



Stretch Your Thinking What if Clue 2 read, "When you subtract Bill's number from 11, you get 3"? How would that change your answer?

Missing Addend Patterns

Write the missing addends. Then look at the missing addends for each group. Describe the pattern that you see.

1. $\square + 6 = 12$

$\square + 6 = 13$

$\square + 6 = 14$

$\square + 6 = 15$

The missing addend: _____

2. $8 + \square = 17$

$8 + \square = 15$

$8 + \square = 13$

$8 + \square = 11$

The missing addend: _____

3. $9 + \square = 11$

$9 + \square = 13$

$9 + \square = 15$

$9 + \square = 17$

The missing addend: _____

4. $\square + 3 = 11$

$\square + 4 = 12$

$\square + 5 = 13$

$\square + 6 = 14$

The missing addend: _____



Stretch Your Thinking Tim knows the whole and one of the parts to a problem. He wants to find the missing part. Use a pattern to write two related facts that will help Tim find the missing addend. Solve.

16, 9, \square

$\underline{\quad} \bigcirc \underline{\quad} \bigcirc \underline{\quad} \square$
 $\underline{\quad} \bigcirc \underline{\quad} \bigcirc \underline{\quad} \square$

$\square = \underline{\quad}$

Finish the Problem

Write the sum or difference. Then finish writing the story problem next to each number sentence.

1. $9 + 7 = \underline{\quad}$	There are 9 children playing ball. _____ _____
2. $15 - 8 = \underline{\quad}$	There are 15 cars in the parking lot. _____ _____
3. $10 - 5 = \underline{\quad}$	Jodi has 10 shirts. _____ _____
4. $6 + 8 = \underline{\quad}$	Mark has 6 rocks. _____ _____



Write a number sentence that uses the numbers 6, 13, and 7. Then write a story problem that goes with the number sentence.

How Many Points?

Six children played a game.

They each scored a different number of points.

Use the clues to tell which trophy belongs to which player.

Write each player's name under his or her trophy.

1. Bill's score is greater than 40 and less than 7 tens.
2. Ann's score is less than 9 tens and greater than 60.
3. Deb's score is greater than 50 and less than 8 tens.
4. Nat's score is greater than 2 tens and less than 5 tens.
5. Julio's score is less than 8 tens and greater than 6 tens.
6. Lily's score is greater than 70 but less than 10 tens.



How did you find out which trophy belongs to Nat?

Get Your Pencils Here

These are the pencils in the supply cabinet at Jen's school. There are 10 pencils in each box.

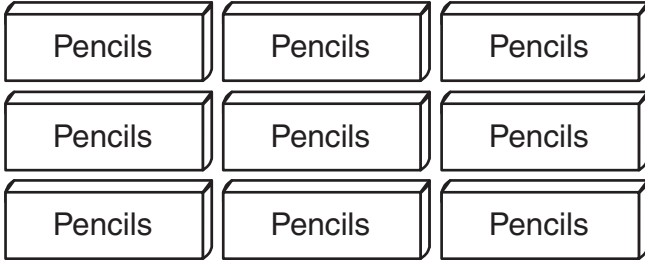

The second grade teachers each take some of the pencils. Read the clues.

Write the number of pencils each teacher takes. Cross out the pencils in the picture to help.

1. Mr. Tabb takes 2 boxes of pencils and 3 other pencils.
2. Mrs. Hart takes 2 boxes of pencils.
3. Miss Moy takes 1 more pencil than Mr. Tabb.
4. Ms. Fano takes 1 more box of pencils than Mrs. Hart.
5. Mr. Erb takes the rest of the pencils.

Mr. Tabb	Mrs. Hart	Miss Moy	Ms. Fano	Mr. Erb
_____	_____	_____	_____	_____
pencils	pencils	pencils	pencils	pencils



How did you find out how many pencils Mr. Erb took?

Least and Greatest

Use 2 of the digits in each set to make the greatest number you can.

Use 2 of the digits in each set to make the least number you can. Then draw  to show the numbers you made.

1.

7

9

8

The greatest 2-digit number is _____

The least 2-digit number is _____

2.

3

7

4

The greatest 2-digit number is _____

The least 2-digit number is _____



When given a set of digits to make the least 2-digit number, in which place value should you put the least digit? Explain.

Follow the Lines

Complete to show the numbers and their meanings.

Write 1, 2, 3, 4, 5, 6, 7, 8, or 9 in each \triangle .

Write 10, 20, 30, 40, 50, 60, 70, 80, or 90 in each \bigcirc .

Write the numbers in each \square .

1.

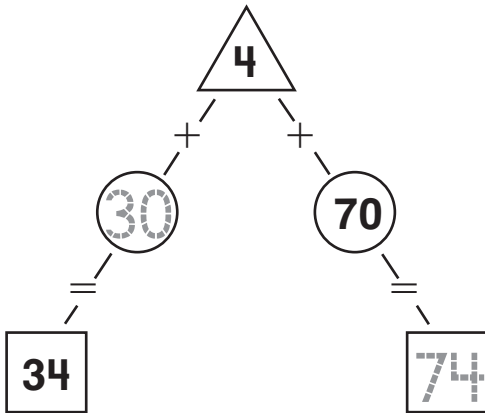

2.

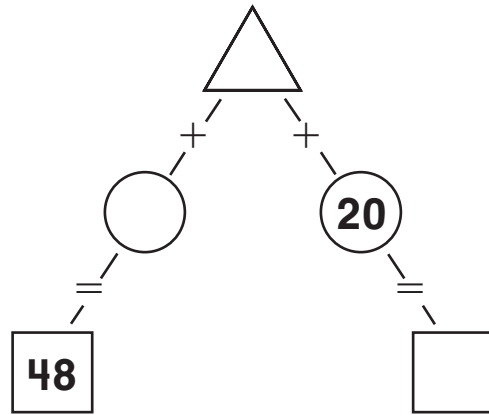

3.

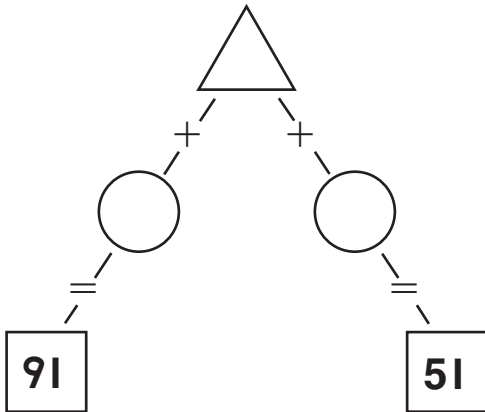

4.

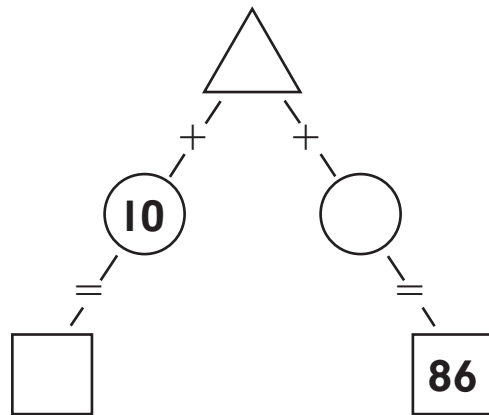

In Exercise 4, how do you know what number to write in the \square ?

More Riddles

Each riddle tells about two of the numbers below it.

Read the riddle. Put an **X** through the number the riddle does **not** tell about.

1. I have fewer than three tens.
My ones digit is 2.

twelve thirty-two twenty-two

2. One of my digits is 5.
My other digit is 9.

five fifty-nine ninety-five

3. The digit 0 is not in my
ones place.

forty four fourteen

4. My tens digit is less than
my ones digit.

fifteen fifty twenty-three

5. The digit 6 is in my
ones place.

six sixty fifty-six

6. My digits are
the same.

eleven twenty-two thirteen

7. My ones digit is greater
than my tens digit.

ten thirty-four twelve

8. The sum of my digits is 9.

thirty-six eighty eighteen



Stretch Your Thinking Write a digit riddle like the riddles on this page. Give it to a classmate to solve.

Match the Models

Kendall modeled some numbers.

The column on the left shows the numbers she modeled.

The column on the right shows how many tens and ones she used in each model.

Find and write the missing numbers.

Then draw a line to connect each number to the number of tens and ones Kendall used to model it.

29	●	●	_____ tens	32 ones
94	●	●	1 ten	_____ ones
37	●	●	8 tens	_____ ones
16	●	●	_____ tens	3 ones
41	●	●	_____ ten	19 ones
73	●	●	2 tens	_____ ones
52	●	●	_____ tens	41 ones



How do you know which model goes with 94?

Planning a Picnic

You are planning a picnic for 20 people.
About how many of each kind of food
should you bring to the picnic?

Write an estimate. Explain why your estimate is reasonable.

1. I would bring about _____ sandwiches, because



sandwich

2. I would bring about _____ watermelons, because



watermelon

3. I would bring about _____ carrot sticks, because

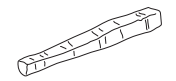

carrot stick

4. I would bring about _____ cookies, because

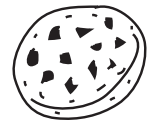

cookie



Stretch Your Thinking What if your picnic was for 40 people? How many cookies would you bring then? Explain.

Color That Train

Al has a toy train with 6 cars. Each car is a different color. Use the clues to color the cars. Write the ordinal numbers.

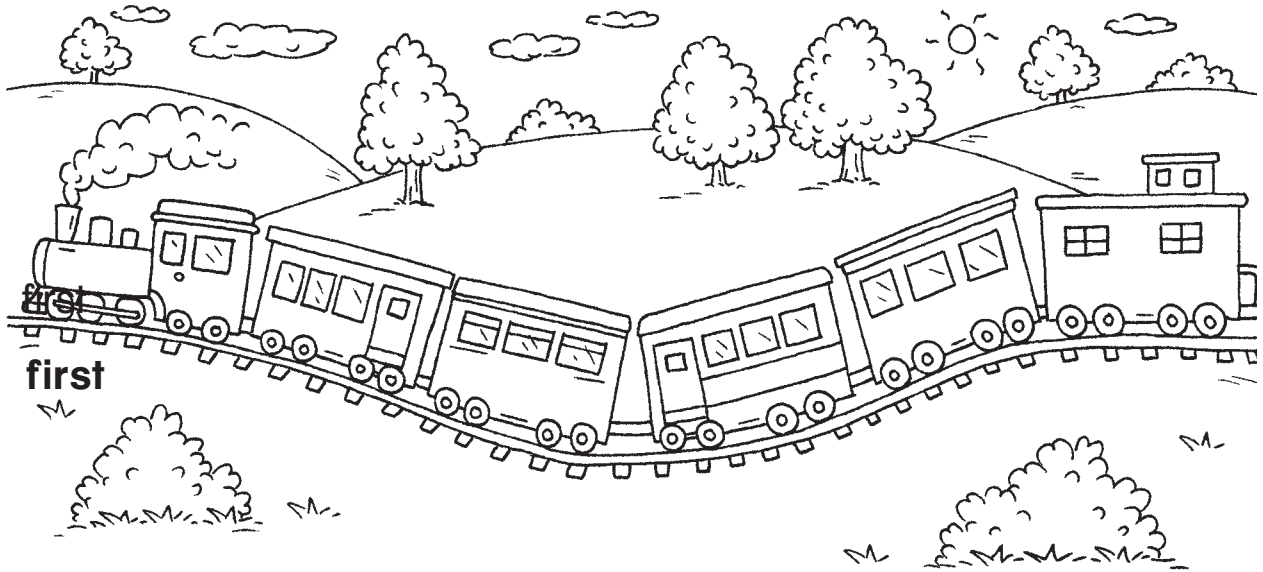

1. The fifth car of the train is blue.
2. The yellow car is between the second car and the sixth car.
3. The red car is two positions after the second car.
4. There are three cars between the green car and the sixth car.
5. The purple car is one position before the green car.
6. The orange car is three positions after the yellow car.

The blue car is 5th.

The red car is _____.

The orange car is _____.

The green car is _____.

The yellow car is _____.

The purple car is _____.



Write a new clue that tells the position of the blue car.

Digit Arrangements

Write two 2-digit numbers in each problem that will make the statement true. Use the digits in the box.

Use each digit only once.

1.

1	7	5	9
---	---	---	---

2.

0	2	0	2
---	---	---	---

_____ > _____

_____ = _____

3.

7	5	5	7
---	---	---	---

4.

2	9	8	2
---	---	---	---

_____ < _____

_____ > _____

5.

7	4	3	4
---	---	---	---

6.

2	1	2	1
---	---	---	---

_____ > _____

_____ < _____

7.

5	5	6	6
---	---	---	---

8.

1	9	4	4
---	---	---	---

_____ = _____

_____ < _____



Look at Exercise 8. Is there another answer that will make this statement true? List some of the other possible answers.

Least to Greatest, Greatest to Least

Write one of the numbers in each blank to make these statements true. Use each number only once.

1.

19	65	52	12	90	88
----	----	----	----	----	----

$$\begin{array}{cccc|cccc} \underline{12} & < & \underline{52} & < & \underline{90} & & \underline{88} & > & \underline{65} & > & \underline{19} \\ \text{least} & & & & \text{greatest} & & \text{greatest} & & & & \text{least} \end{array}$$

2.

36	38	11	39	30	13
----	----	----	----	----	----

$$\begin{array}{cccc|cccc} \underline{\quad} & < & \underline{\quad} & < & \underline{\quad} & & \underline{\quad} & > & \underline{\quad} & > & \underline{\quad} \\ \text{least} & & & & \text{greatest} & & \text{greatest} & & & & \text{least} \end{array}$$

3.

52	72	92	22	42	65
----	----	----	----	----	----

$$\begin{array}{cccc|cccc} \underline{\quad} & < & \underline{\quad} & < & \underline{\quad} & & \underline{\quad} & > & \underline{\quad} & > & \underline{\quad} \\ \text{least} & & & & \text{greatest} & & \text{greatest} & & & & \text{least} \end{array}$$

4.

18	81	47	74	76	67
----	----	----	----	----	----

$$\begin{array}{cccc|cccc} \underline{\quad} & < & \underline{\quad} & < & \underline{\quad} & & \underline{\quad} & > & \underline{\quad} & > & \underline{\quad} \\ \text{least} & & & & \text{greatest} & & \text{greatest} & & & & \text{least} \end{array}$$

5.

43	16	52	54	49	80
----	----	----	----	----	----

$$\begin{array}{cccc|cccc} \underline{\quad} & < & \underline{\quad} & < & \underline{\quad} & & \underline{\quad} & > & \underline{\quad} & > & \underline{\quad} \\ \text{least} & & & & \text{greatest} & & \text{greatest} & & & & \text{least} \end{array}$$



Stretch Your Thinking Look at Exercise 5. Where can you write the number 80? Explain.

Be a Basketball Detective

Five children are on a basketball team.
Use the clues to find the children's shirt numbers.
Write each child's shirt number below.

1. Tim's number rounds to 90.
Both of its digits are the same.
2. Lee's number rounds to 30.
Its tens digit is 1 more than its ones digit.
3. Taya's number rounds to 70.
Its tens digit is 1 less than its ones digit.
4. Cole's number rounds to 50.
It has more than 8 ones.
5. Alice's number rounds to 30.
If you add 2 to it, it will round to 40.

Tim

Lee

Taya

Cole

Alice



Write a clue for a 2-digit number.

Tell which ten it rounds to as part of the clue.

Even Sums, Odd Sums

Find the sums. Write **even** or **odd**.

Look for patterns.

1. $7 + 5 = \underline{12}$ $\underline{\text{odd}} + \underline{\text{odd}} = \underline{\text{even}}$	2. $3 + 7 = \underline{\quad}$ $\underline{\quad} + \underline{\quad} = \underline{\quad}$
3. $9 + 9 = \underline{\quad}$ $\underline{\quad} + \underline{\quad} = \underline{\quad}$	4. $5 + 9 = \underline{\quad}$ $\underline{\quad} + \underline{\quad} = \underline{\quad}$
5. $8 + 6 = \underline{\quad}$ $\underline{\quad} + \underline{\quad} = \underline{\quad}$	6. $4 + 10 = \underline{\quad}$ $\underline{\quad} + \underline{\quad} = \underline{\quad}$
7. $6 + 4 = \underline{\quad}$ $\underline{\quad} + \underline{\quad} = \underline{\quad}$	8. $8 + 8 = \underline{\quad}$ $\underline{\quad} + \underline{\quad} = \underline{\quad}$
9. $8 + 5 = \underline{\quad}$ $\underline{\quad} + \underline{\quad} = \underline{\quad}$	10. $10 + 7 = \underline{\quad}$ $\underline{\quad} + \underline{\quad} = \underline{\quad}$
11. $5 + 6 = \underline{\quad}$ $\underline{\quad} + \underline{\quad} = \underline{\quad}$	12. $9 + 8 = \underline{\quad}$ $\underline{\quad} + \underline{\quad} = \underline{\quad}$



What patterns do you see?

More About Skip-Counting

Ken is skip-counting by different numbers. He starts counting at 0. Read the clues. Circle the number he could be counting by.

1. Ken shades 20, 25, and 30 on the hundred chart. He is counting by:

_____.

twos fives tens

2. Ken shades 76, 78, and 80 on the hundred chart. He could be counting by:

_____.

twos fours tens

3. Ken shades 15, 18, and 21 on the hundred chart. He could be counting by:

_____.

twos threes fours

5. Ken shades 50 on the hundred chart. He could be counting by:

_____.

twos threes fours

1	2	3	4	5	6	7	8	9	10
11	12	13	14	15	16	17	18	19	20
21	22	23	24	25	26	27	28	29	30
31	32	33	34	35	36	37	38	39	40
41	42	43	44	45	46	47	48	49	50
51	52	53	54	55	56	57	58	59	60
61	62	63	64	65	66	67	68	69	70
71	72	73	74	75	76	77	78	79	80
81	82	83	84	85	86	87	88	89	90
91	92	93	94	95	96	97	98	99	100

4. Ken shades 24 and 28 on the hundred chart. He could be counting by:

_____.

threes fours fives

6. Ken shades 65 on the hundred chart. He could be counting by:

_____.

threes fours fives



How did you solve Exercise 6?

Patterns and Problems

Find which table goes with each of the stories.

Complete each table. Then find the pattern to solve.

There are 7 cows. Each cow has 4 spots.	There are 7 fish. Each fish has 2 eyes.	There are 7 tigers. Each tiger has 10 stripes.
---	--	--

1. How many _____ are on 7 _____?

number of _____	1	2	3	4	5	6	7
number of _____			30	40	50		

There are _____ on 7 _____.

2. How many _____ are on 7 _____?

number of _____	1	2	3	4	5	6	7
number of _____			12	16	20		

There are _____ on 7 _____.

3. How many _____ are on 7 _____?

number of _____	1	2	3	4	5	6	7
number of _____			6	8	10		

There are _____ on 7 _____.



Stretch Your Thinking Look at the table in Exercise 2.

How did you find the story to match?

Two Number Patterns

Read the clues to solve.

Use a hundred chart to help you.

1.



Jack

I am skip-counting by fives. I start my pattern with 16.

I am skip-counting by twos. I start my pattern with 13.



Tina

Write a number that is in both Jack's and Tina's patterns. _____

2.

I am skip-counting by tens. I start my pattern with 29.



Pam



Matt

I am skip-counting by twos. I start my pattern with 81.

Write a number that is in both Pam's and Matt's patterns. _____

3.



Sean

I am skip-counting by fives. I start my pattern with 18.

I am skip-counting by tens. I start my pattern with 63.

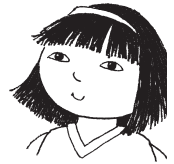

Zoe

Write a number that is in both Sean's and Zoe's patterns. _____



Stretch Your Thinking If they count up to 100, are there any numbers that will be in all six of the children's patterns? Explain.

What Number Am I?

Read the clues. Write the number.

1. I am 3 more tens than 17.
What number am I?

47

2. I am 40 more than 25.
What number am I?

3. I am 6 more tens than 12.
What number am I?

4. I am 2 more tens than 64.
What number am I?

5. I am 20 more than 34.
What number am I?

6. I am 8 more tens than 11.
What number am I?

7. I am 4 more tens than 30.
What number am I?

8. I am 2 more tens than 68.
What number am I?

9. I am 50 more than 23.
What number am I?

10. I am 3 more tens than 54.
What number am I?



Stretch Your Thinking Think of a number.
Write a clue that can be used to find that number.

Story Problem Fun

Complete the problems. Write numbers in the blanks.
Use a 1-digit number and a 2-digit number in each problem. Use Workmat 11 and  to solve.

1. Ian has 14 toy cars. Lucas has 7 more toy cars than Ian. How many toy cars does Lucas have?



toy car

25

toy cars

2. Emmy has _____ blue markers and _____ green markers. How many markers does Emmy have in all?



marker

_____ markers

3. Sara has _____ blocks.

Marta has _____ more blocks than Sara. How many blocks does Marta have?



block

_____ blocks

4. Tom has _____ pennies. Maria gives him _____ more pennies. How many pennies does Tom have now?



penny

_____ pennies



Stretch Your Thinking Write a problem like the ones above. Ask a classmate to write numbers in it and solve.

Write the Addition Problem

The workmats show the sums for addition problems. Write an addition problem for each workmat.

1. **Workmat**

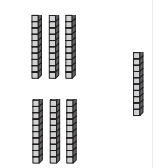
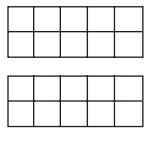
Tens	Ones
	

Add 37 and 33.

2. **Workmat**

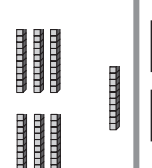
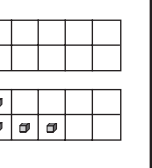
Tens	Ones
	

Add ____ and ____.

3. **Workmat**

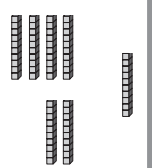
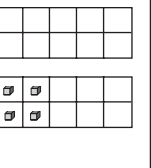
Tens	Ones
	

Add ____ and ____.

4. **Workmat**

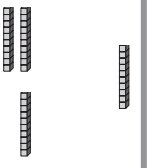
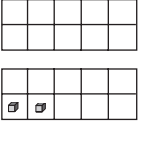
Tens	Ones
	

Add ____ and ____.

5. **Workmat**

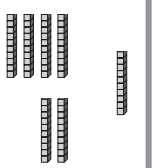
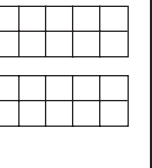
Tens	Ones
	

Add ____ and ____.

6. **Workmat**

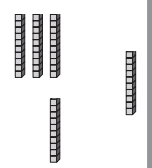
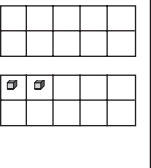
Tens	Ones
	

Add ____ and ____.

7. **Workmat**

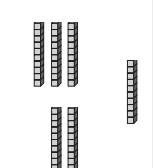
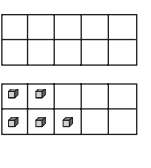
Tens	Ones
	

Add ____ and ____.

8. **Workmat**

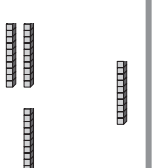
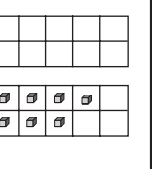
Tens	Ones
	

Add ____ and ____.

9. **Workmat**

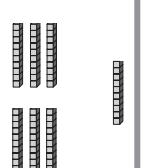
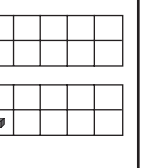
Tens	Ones
	

Add ____ and ____.



Stretch Your Thinking Write another addition problem for the Workmat in Exercise 9.

What is the Problem?

The models below can be used to solve problems.

Write a problem for each model.

Use Workmat II and  to solve the problem.

1. **Workmat**

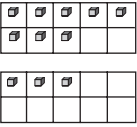
Tens	Ones
	



Joan sees 48 bees. Dan sees 33 bees. How many bees do they see in all?

81 bees

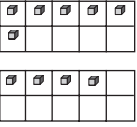
2. **Workmat**

Tens	Ones
	

3. **Workmat**

Tens	Ones
	



Stretch Your Thinking Write a story problem.
Have a classmate draw the tens and ones to solve.

Find the Errors

Find the errors in the addition problems. Circle them.
 Then show how to do the problem correctly.
 Use Workmat 3 and  if you need to.

1.

Tens	Ones
<input type="text" value="1"/>	2
4	9
<hr/>	
5	1

Tens	Ones
<input type="text" value="1"/>	2
4	9
<hr/>	
6	1

2.

Tens	Ones
<input type="text" value="1"/>	
2	7
5	6
<hr/>	
8	2

Tens	Ones
<input type="text" value=""/>	
2	7
5	6
<hr/>	

3.

Tens	Ones
<input type="text" value="2"/>	
4	5
3	6
<hr/>	
9	1

Tens	Ones
<input type="text" value=""/>	
4	5
3	6
<hr/>	

4.

Tens	Ones
<input type="text" value=""/>	
7	2
1	8
<hr/>	
8	0

Tens	Ones
<input type="text" value=""/>	
7	2
1	8
<hr/>	

5.

Tens	Ones
<input type="text" value="1"/>	
3	3
2	6
<hr/>	
6	9

Tens	Ones
<input type="text" value=""/>	
3	3
2	6
<hr/>	

6.

Tens	Ones
<input type="text" value="1"/>	
5	9
2	3
<hr/>	
9	2

Tens	Ones
<input type="text" value=""/>	
5	9
2	3
<hr/>	



What error did you find in Exercise 5?

Arrange the Digits

Arrange the digits in the empty boxes to make the addition problem true. Use Workmat 3 and  if you need to.

1.

	7	3	
2	1	2	2
	2	7	
+	2	3	
	5	0	

2.

	8	7	
2			1
+			
	4	5	

3.

	4	5	
6			2
+			
	7	1	

4.

	3	2	
4			1
+			
	7	3	

5.

	3	8	
7			4
+			
	8	5	

6.

	3	5	
9			4
+			
	9	3	



Is there another way you could have arranged the digits in Exercise 6? Explain.

How Does It Add Up?

Use the three numbers to write an addition problem. Then write a story problem that can be solved by the addition problem.

<p>1. 35 17 18</p> <table border="1" style="display: inline-table; vertical-align: middle;"> <thead> <tr> <th style="width: 50px;">Tens</th> <th style="width: 50px;">Ones</th> </tr> </thead> <tbody> <tr> <td style="text-align: center;"> </td> <td></td> </tr> <tr> <td style="text-align: center;"> </td> <td style="text-align: center;">7</td> </tr> <tr> <td style="text-align: center;"> </td> <td style="text-align: center;">8</td> </tr> <tr> <td style="text-align: center;">+</td> <td></td> </tr> <tr> <td style="text-align: center;"> </td> <td style="text-align: center;">5</td> </tr> <tr> <td style="text-align: center;">3</td> <td></td> </tr> </tbody> </table>	Tens	Ones				7		8	+			5	3		<p>Ann has 17 stickers.</p> <hr/> <hr/> <hr/> <hr/>
Tens	Ones														
	7														
	8														
+															
	5														
3															
<p>2. 38 62 24</p> <table border="1" style="display: inline-table; vertical-align: middle;"> <thead> <tr> <th style="width: 50px;">Tens</th> <th style="width: 50px;">Ones</th> </tr> </thead> <tbody> <tr> <td style="text-align: center;">□</td> <td></td> </tr> <tr> <td></td> <td></td> </tr> <tr> <td style="text-align: center;">+</td> <td></td> </tr> <tr> <td></td> <td></td> </tr> </tbody> </table>	Tens	Ones	□				+				<hr/> <hr/> <hr/> <hr/>				
Tens	Ones														
□															
+															
<p>3. 43 27 16</p> <table border="1" style="display: inline-table; vertical-align: middle;"> <thead> <tr> <th style="width: 50px;">Tens</th> <th style="width: 50px;">Ones</th> </tr> </thead> <tbody> <tr> <td style="text-align: center;">□</td> <td></td> </tr> <tr> <td></td> <td></td> </tr> <tr> <td style="text-align: center;">+</td> <td></td> </tr> <tr> <td></td> <td></td> </tr> </tbody> </table>	Tens	Ones	□				+				<hr/> <hr/> <hr/> <hr/>				
Tens	Ones														
□															
+															



How did you decide where the numbers should go in each addition problem?

The Lost Digits

These addition problems are missing some digits.
Can you put them back where they belong?

Write the correct digit in each of the boxes.
Use each digit in the cloud only once.

Tens	Ones
<input type="text"/>	
4	7
+ 1	<input type="text"/>
6	2

Tens	Ones
<input type="text"/>	
3	5
+ 4	8
8	

Tens	Ones
<input type="text"/>	
1	7
+ <input type="text"/>	3
8	0

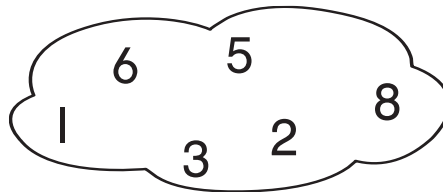

Tens	Ones
<input type="text"/>	
3	<input type="text"/>
+ 2	7
6	5

Tens	Ones
<input type="text"/>	
<input type="text"/>	6
+ 4	5
7	1

Tens	Ones
<input type="text"/>	
2	<input type="text"/>
+ 1	9
4	0



Stretch Your Thinking Write your own addition problem with a missing digit. Then have a classmate find the missing digit.

Tens	Ones
<input type="text"/>	
+ <input type="text"/>	

How Many Could There Be?

There are 40 children on Meg's street. There are more boys than girls. The number of both boys and girls is greater than 9. Write some of the possible 2-digit addition problems that show how many boys and girls there could be. Use an addend only once.

$$\begin{array}{r|l} \square & \\ 3 & 0 \\ + 1 & 0 \\ \hline 4 & 0 \end{array}$$

$$\begin{array}{r|l} \square & \\ + & \end{array}$$

$$\begin{array}{r|l} \square & \\ + & \end{array}$$

$$\begin{array}{r|l} \square & \\ + & \end{array}$$

$$\begin{array}{r|l} \square & \\ + & \end{array}$$

$$\begin{array}{r|l} \square & \\ + & \end{array}$$

$$\begin{array}{r|l} \square & \\ + & \end{array}$$

$$\begin{array}{r|l} \square & \\ + & \end{array}$$

$$\begin{array}{r|l} \square & \\ + & \end{array}$$

$$\begin{array}{r|l} \square & \\ + & \end{array}$$



Explain why $20 + 20 = 40$ is not used.

Estimation Challenge

Solve these problems without using a number line.

Round each addend to the nearest ten.

Find the estimated sum.

1. Kirk scores 16 points in the first half of the basketball game. He scores 13 points in the second half. About how many points does he score in all?



basketball

$$\begin{array}{r} 16 \longrightarrow \boxed{} \\ + 13 \longrightarrow + \boxed{} \\ \hline \boxed{} \end{array}$$

about _____ points

2. Sadie makes 17 pitches at the beginning of softball practice. She also makes 22 pitches at the end of practice. About how many pitches does she make in all?



softball

$$\begin{array}{r} 17 \longrightarrow \boxed{} \\ + 22 \longrightarrow + \boxed{} \\ \hline \boxed{} \end{array}$$

about _____ pitches

3. There are 23 children on Andrew's swim team. There are 36 children on Leah's swim team. About how many children are there on both swim teams together?

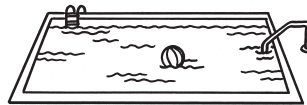

swimming pool

$$\begin{array}{r} 23 \longrightarrow \boxed{} \\ + 36 \longrightarrow + \boxed{} \\ \hline \boxed{} \end{array}$$

about _____ children



Stretch Your Thinking Write your own problem in which you estimate to solve.

Mystery Addends

Use the clues and the given sum to help you find the addends. Complete the addition problem.

1. The first addend is 2 more than 15. The second addend is 2 more than the first addend.

$$\begin{array}{r} + 7 \\ 19 \\ \hline 36 \end{array}$$

2. The first addend is 5 more than 30. The second addend is 10 less than the first addend.

$$\begin{array}{r} + \\ \hline 60 \end{array}$$

3. The first addend is 4 more than 30.

$$\begin{array}{r} + \\ \hline 71 \end{array}$$

4. The first addend is 5 more than 20.

$$\begin{array}{r} + \\ \hline 42 \end{array}$$

5. The first addend is 5 more than the second addend.

$$\begin{array}{r} + \\ \hline 25 \end{array}$$

6. The two addends are the same.

$$\begin{array}{r} + \\ \hline 48 \end{array}$$



How did you solve Exercise 6?

Missing Points

Complete the table by solving the problems below.

Points Scored in Soccer Game	
Player	Number of Points
Anton	39
Liza	
Sasha	
Milo	28

1. Liza scored 17 more points than Milo.
How many points did Liza score?

_____ points

-
2. Sasha and Liza scored a total of 94 points.
How many points did Sasha score?

_____ points

-
3. Who scored the most points in the soccer game? _____



Explain how you solved Exercise 3.

Which Toys?

Look at the prices of the toys.
Complete the addition problems.



1. Jason buys two toys for exactly 76¢. One of the toys is a top. What other toy does Jason buy?

$$\begin{array}{c} \underline{\quad\quad} \\ \swarrow \quad \searrow \\ \text{cloud} \\ \underline{\quad} + \underline{\quad} \end{array} + \begin{array}{c} \underline{\quad\quad} \\ \swarrow \quad \searrow \\ \text{cloud} \\ \underline{\quad} + \underline{\quad} \end{array} = \underline{\quad\quad}$$

2. Henry buys two toys for exactly 84¢.
Which two toys might he buy?

$$\begin{array}{c} \underline{\quad\quad} \\ \swarrow \quad \searrow \\ \text{cloud} \\ \underline{\quad} + \underline{\quad} \end{array} + \begin{array}{c} \underline{\quad\quad} \\ \swarrow \quad \searrow \\ \text{cloud} \\ \underline{\quad} + \underline{\quad} \end{array} = \underline{\quad\quad}$$

_____ and _____



Stretch Your Thinking Is there another answer for Exercise 2? Explain.

How Many Tens?

How many tens should be subtracted to make each sentence true?

Write the number of tens.

1. $32 - \underline{2}$ tens = 12

2. $49 - \underline{\quad}$ tens = 19

3. $58 - \underline{\quad}$ tens = 28

4. $87 - \underline{\quad}$ tens = 37

5. $92 - \underline{\quad}$ tens = 72

6. $55 - \underline{\quad}$ tens = 15

7. $43 - \underline{\quad}$ tens = 23

8. $82 - \underline{\quad}$ tens = 52

9. $98 - \underline{\quad}$ tens = 28

10. $59 - \underline{\quad}$ tens = 39

11. $78 - \underline{\quad}$ tens = 48

12. $63 - \underline{\quad}$ tens = 23

13. $91 - \underline{\quad}$ tens = 11

14. $75 - \underline{\quad}$ tens = 45

15. $64 - \underline{\quad}$ tens = 44

16. $33 - \underline{\quad}$ tens = 13



Stretch Your Thinking Choose a number from 1 to 5. Write a number sentence in which that number of tens is subtracted from another number.

Subtract to Match

Match each number sentence to the number that it is missing. Use Workmat 11 and  if you need to.

- | | | | |
|------------------|---|---|----|
| 1. $36 - ? = 28$ | ● | ● | 2 |
| 2. $? - 7 = 35$ | ● | ● | 55 |
| 3. $51 - ? = 47$ | ● | ● | 8 |
| 4. $62 - ? = 59$ | ● | ● | 35 |
| 5. $? - 9 = 46$ | ● | ● | 4 |
| 6. $24 - ? = 19$ | ● | ● | 24 |
| 7. $? - 6 = 29$ | ● | ● | 3 |
| 8. $81 - ? = 79$ | ● | ● | 42 |
| 9. $? - 9 = 15$ | ● | ● | 5 |







How did you solve Exercise 9?



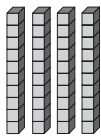
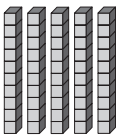
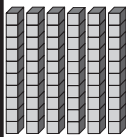
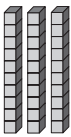
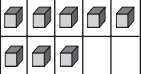

Match the Mats

Look at the numbers in the center. Each number has been subtracted from one of the numbers shown above it. One of the workmats below it shows the difference.

Color to match the parts of the subtraction sentence the same color.

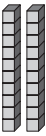
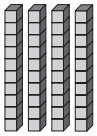
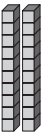
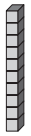
Workmat	Workmat	Workmat	Workmat
Tens Ones	Tens Ones	Tens Ones	Tens Ones
			
			

(18)	(27)	(11)	(36)
	—		
	=		

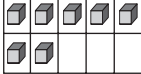
Workmat	Workmat	Workmat	Workmat
Tens Ones	Tens Ones	Tens Ones	Tens Ones
			
			



Stretch Your Thinking Could you have used addition to match the numbers to the Workmats? Explain.

Follow the Clues

Read the clues. Use Workmat 11 and . Write how many.

1. Sara paints 4 more than 10 postcards.
She gives away 4 less than 10 of her postcards.
How many postcards does she have left?



postcard

_____ postcards

2. Keith makes 3 more than 20 puppets.
He gives 6 less than 20 of them to his sister.
How many puppets does he have left?



puppet

_____ puppets

3. Ross fingerpaints 8 more than 20 pictures.
He gives away 3 less than 20 of his pictures.
How many pictures does he have left?

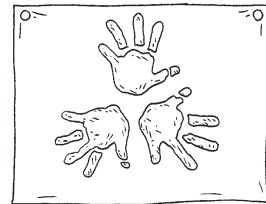

picture

_____ pictures



Stretch Your Thinking Read the problem. Write clues to replace the numbers. Then solve the problem.

Troy has 26 markers. 17 markers are blue. The rest of the markers are red. How many of the markers are red?

Balancing Amounts

Each balance is missing a number.
Find the number that will make the balance level.
Write the number in the box. Use each number
only once.

3

8

5

6

4

7

1. $15 - 9 = \square$

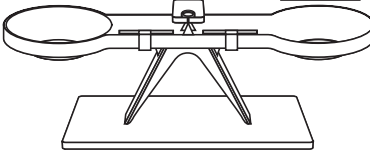

2. $33 - \square = 28$

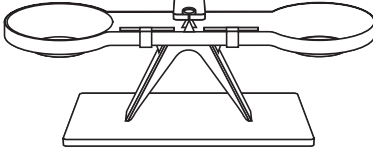

3. $22 - \square = 19$

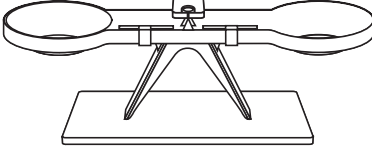

4. $31 - \square = 27$

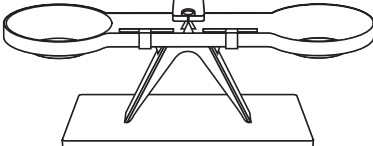

5. $53 - \square = 46$

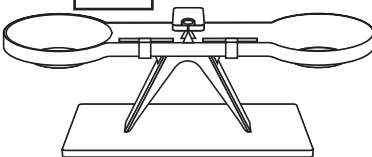

6. $29 - 21 = \square$

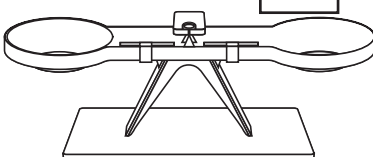

WRITE Math

How did you find out which number belongs on the balance in Exercise 4?

Subtraction Wheels

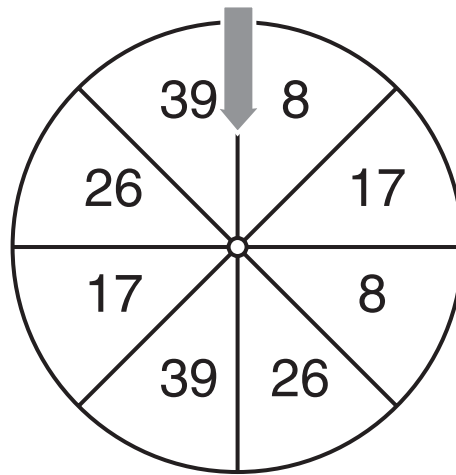
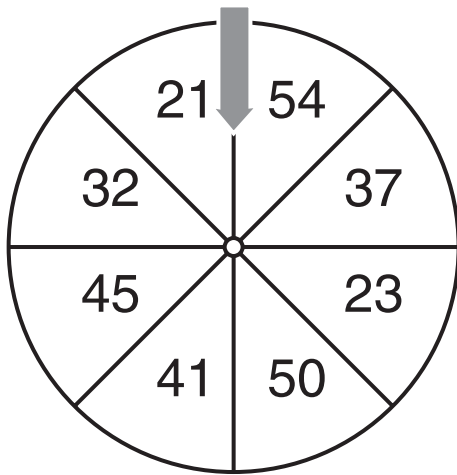

Brett gives each wheel one spin.
He finds that the difference between the numbers
is 15. Which two numbers does Brett spin?

_____ and _____

Brett spins the wheels again.
Both wheels stop on different numbers,
but Brett still finds that the difference is 15.
Which two numbers does
Brett spin this time?

_____ and _____



Stretch Your Thinking How many more ways
could Brett spin two numbers with a difference of 15?
List all the different ways.

Fill in the Blanks

Write 2-digit numbers in the blanks. Solve.

1. Lucy has 37 marbles. She puts 18 marbles in a bag. How many marbles are not in the bag?



marble

19 marbles

Tens	Ones
2	7
3	7
-	1
1	8
1	9

2. Toby has _____ blocks. He puts _____ blocks on a shelf and the rest in a box. How many blocks does he put in the box?



block

_____ blocks

Tens	Ones
-	

3. Eric puts _____ model airplanes on a shelf. He has _____ model airplanes in all. How many are not on the shelf?



model airplane

_____ model airplanes

Tens	Ones
-	

4. Alice has _____ beads. She uses some to make a bracelet. She has _____ beads left. How many beads does she use to make the bracelet?



bead

_____ beads

Tens	Ones
-	



Write a problem that you can subtract to solve.

Two-Step Problems

Subtract to solve each problem. Regroup if you need to.

1. Mike has 42 toy trucks. Suzy has 3 more toy trucks than Mike. Juan has 29 fewer toy trucks than Suzy. How many toy trucks does Juan have?

**toy truck**

_____ toy trucks

Tens	Ones
□	□
—	

2. Jamal has 82 trading cards. Laura has 8 more trading cards than Jamal. Henry has 35 fewer trading cards than Laura. How many trading cards does Henry have?

**trading card**

_____ trading cards

Tens	Ones
□	□
—	

3. Jen has 32 building blocks. Sue has 7 more building blocks than Jen. Maria has 16 fewer building blocks than Sue. How many building blocks does Maria have?

**building block**

_____ building blocks

Tens	Ones
□	□
—	



How did you find the number to subtract from to solve Exercise 2?

Jumbled Numbers

Rewrite the numbers below to make subtraction problems with regrouping. Use each number only once. Then solve.

63	45	27	18	9	54	72	81	36	90
----	----	----	----	---	----	----	----	----	----

Tens	Ones
□	□
-	

Tens	Ones
□	□
-	

Tens	Ones
□	□
-	

Tens	Ones
□	□
-	

Tens	Ones
□	□
-	



How did you check if you had to regroup to solve the problems?

The Same Difference

Write and solve two subtraction problems that show how many of each there might be. Then write the numbers.

1. There are four different kinds of fruit at the store.
There is a different number of each kind of fruit.
There are 28 more bananas than pears.
There are 28 more apples than oranges.
There are more pears than apples.

_____ bananas
_____ pears
_____ apples
_____ oranges

2. There are four different kinds of animals on the farm.
There is a different number of each kind of animal.
There are 19 more cows than sheep.
There are 19 more ducks than hens.
There are more hens than cows.

_____ cows
_____ sheep
_____ ducks
_____ hens



How did you find the numbers in Exercise 2?

Add to Subtract

Julie solved some subtraction problems. Then she used addition to check her answers. Now solve each addition problem. Write the subtraction problem to check your answers. Then subtract.

Addition	Subtraction	Addition	Subtraction
1. $\begin{array}{r} 18 \\ + 16 \\ \hline 34 \end{array}$	$\begin{array}{r} 24 \\ 34 \\ - 16 \\ \hline 18 \end{array}$	2. $\begin{array}{r} 13 \\ + 48 \\ \hline \end{array}$	$\begin{array}{r} \\ \\ - \\ \hline \end{array}$
3. $\begin{array}{r} 38 \\ + 35 \\ \hline \end{array}$	$\begin{array}{r} \\ \\ - \\ \hline \end{array}$	4. $\begin{array}{r} 29 \\ + 17 \\ \hline \end{array}$	$\begin{array}{r} \\ \\ - \\ \hline \end{array}$
5. $\begin{array}{r} 28 \\ + 57 \\ \hline \end{array}$	$\begin{array}{r} \\ \\ - \\ \hline \end{array}$	6. $\begin{array}{r} 54 \\ + 27 \\ \hline \end{array}$	$\begin{array}{r} \\ \\ - \\ \hline \end{array}$
7. $\begin{array}{r} 64 \\ + 28 \\ \hline \end{array}$	$\begin{array}{r} \\ \\ - \\ \hline \end{array}$	8. $\begin{array}{r} 79 \\ + 19 \\ \hline \end{array}$	$\begin{array}{r} \\ \\ - \\ \hline \end{array}$



Look at the last addition problem.

Is there more than one subtraction problem that can be used to check?

Find the Mistake

Circle the mistake in each problem.

Write the correct numbers. Find the correct estimate.

<p>1.</p> $\begin{array}{r} 88 \longrightarrow \boxed{80} \\ -72 \longrightarrow - \boxed{70} \\ \hline \end{array}$ <p style="text-align: center;">20 $\boxed{10}$</p>	<p>2.</p> $\begin{array}{r} 67 \longrightarrow \boxed{70} \\ -52 \longrightarrow - \boxed{60} \\ \hline \end{array}$ <p style="text-align: center;">$\boxed{10}$</p>	<p>3.</p> $\begin{array}{r} 78 \longrightarrow \boxed{80} \\ -56 \longrightarrow - \boxed{50} \\ \hline \end{array}$ <p style="text-align: center;">$\boxed{30}$</p>
<p>4.</p> $\begin{array}{r} 69 \longrightarrow \boxed{70} \\ -58 \longrightarrow - \boxed{50} \\ \hline \end{array}$ <p style="text-align: center;">$\boxed{20}$</p>	<p>5.</p> $\begin{array}{r} 86 \longrightarrow \boxed{80} \\ -51 \longrightarrow - \boxed{50} \\ \hline \end{array}$ <p style="text-align: center;">$\boxed{30}$</p>	<p>6.</p> $\begin{array}{r} 73 \longrightarrow \boxed{80} \\ -41 \longrightarrow - \boxed{40} \\ \hline \end{array}$ <p style="text-align: center;">$\boxed{40}$</p>
<p>7.</p> $\begin{array}{r} 63 \longrightarrow \boxed{70} \\ -57 \longrightarrow - \boxed{60} \\ \hline \end{array}$ <p style="text-align: center;">$\boxed{10}$</p>	<p>8.</p> $\begin{array}{r} 76 \longrightarrow \boxed{70} \\ -54 \longrightarrow - \boxed{50} \\ \hline \end{array}$ <p style="text-align: center;">$\boxed{20}$</p>	<p>9.</p> $\begin{array}{r} 68 \longrightarrow \boxed{70} \\ -56 \longrightarrow - \boxed{50} \\ \hline \end{array}$ <p style="text-align: center;">$\boxed{20}$</p>



How did the rounding mistakes change the estimates?

Use the Method

Write a problem that is best solved by each method.
Then use the methods to solve the problems.

<p>1. Use mental math.</p> <hr/> <hr/> <hr/> <hr/>	<hr/>
<p>2. Use paper and pencil.</p> <hr/> <hr/> <hr/> <hr/>	<hr/>
<p>3. Use a calculator.</p> <hr/> <hr/> <hr/> <hr/>	<hr/>



How did you choose the numbers you wrote in the mental math problem?

Where to Start?

Tracy used mental math to solve some subtraction problems. Find the numbers Tracy started with. Write the subtraction sentences she solved. Then find the differences.

<p>1.</p> $\underline{\quad} + 4 = 57$ $\underline{\quad} + 4 = 20$	$\begin{array}{r} 57 \\ - 20 \\ \hline \square \end{array}$	<p>So,</p> $\begin{array}{r} \square \\ - \square \\ \hline \square \end{array}$
<p>2.</p> $\underline{\quad} + 5 = 61$ $\underline{\quad} + 5 = 40$	$\begin{array}{r} 61 \\ - 40 \\ \hline \square \end{array}$	<p>So,</p> $\begin{array}{r} \square \\ - \square \\ \hline \square \end{array}$
<p>3.</p> $\underline{\quad} + 7 = 83$ $\underline{\quad} + 7 = 50$	$\begin{array}{r} 83 \\ - 50 \\ \hline \square \end{array}$	<p>So,</p> $\begin{array}{r} \square \\ - \square \\ \hline \square \end{array}$
<p>4.</p> $\underline{\quad} + 9 = 76$ $\underline{\quad} + 9 = 30$	$\begin{array}{r} 76 \\ - 30 \\ \hline \square \end{array}$	<p>So,</p> $\begin{array}{r} \square \\ - \square \\ \hline \square \end{array}$



Look at Exercise 4. How did you find the numbers that Tracy started with?

A Pair of Problems

Find the sum or difference for part **A** in each problem.
Then use the answer to solve part **B**.

- A.** Kim has 35 beads. She gives 18 beads to Callie. How many beads does Kim have now?



bead

_____ beads

- B.** Callie gives 9 beads back to Kim. How many beads does Kim have now?

_____ beads

- A.** Jon and Eli each have 32 pennies. How many pennies do they have in all?



penny

_____ pennies

- B.** Jon and Eli give 15 of their combined pennies to Tim. How many pennies do Jon and Eli have now?

_____ pennies

- A.** Kate has 43 blocks. Alex has 18 blocks. Kate gives 8 blocks to Alex. How many blocks do they each have now?



block

Kate: _____ blocks

Alex: _____ blocks

- B.** How many more blocks does Kate have than Alex?

_____ more blocks



Stretch Your Thinking Write a problem with a part A and a part B. Trade your problem with a classmate and solve.

Missing Survey Data

Eric took 3 surveys of his classmates.
He forgot to record their answers!
Use the clues to help Eric fill in his tally tables.

1. Clues:

- Eric surveyed 12 classmates.
- The most classmates chose chocolate.
- One more classmate chose strawberry than vanilla.

Favorite Ice Cream	
Flavor	Tally
chocolate	
vanilla	
strawberry	

2. Clues:

- Eric surveyed 22 classmates.
- The fewest classmates chose baseball.
- The same number of classmates chose soccer and swimming.

Favorite Sport	
Sport	Tally
soccer	
baseball	
swimming	

3. Clues:

- The most classmates chose dinner.
- Seven classmates chose breakfast.
- Eric surveyed 32 classmates.

Favorite Meal	
Meal	Tally
breakfast	
lunch	
dinner	



Look at Exercise 3. How did you decide how many tally marks to put in each row?

Sunflower Growth

Mae grows a sunflower. She draws and records the height on Days 1 and 4. Draw how the sunflower may have looked on Days 2 and 3. Record the heights.



Day 1



Day 2



Day 3



Day 4

Sunflower Growth	
Day	Height
Day 1	2 centimeters
Day 2	_____ centimeters
Day 3	_____ centimeters
Day 4	8 centimeters



Stretch Your Thinking Between which two days did the sunflower grow the most?

between Day _____ and Day _____

Summer Bar Graph

Annabelle tells about her summer using a bar graph. She shows the number of days she spent doing each activity, but forgets to write the activities! Help Annabelle complete her bar graph.

- Annabelle spent the least amount of time babysitting.
- Annabelle did not take an art class.
- Annabelle spent 2 fewer days at camp than she did volunteering.
- Annabelle went to the beach with her family.

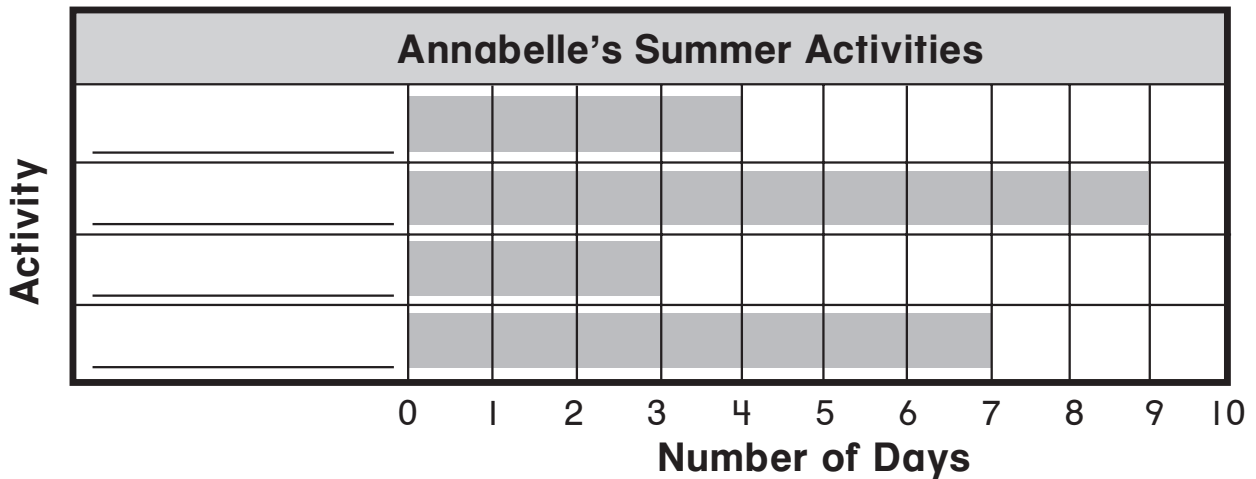

Which clue was the least helpful? Explain.

Grocery Basket Graphs

Henry goes grocery shopping.
 He buys four different kinds of items.
 He buys a different number of each item.
 Draw how many of each item Henry buys.
 Then fill in the bar graph to show what he buys.

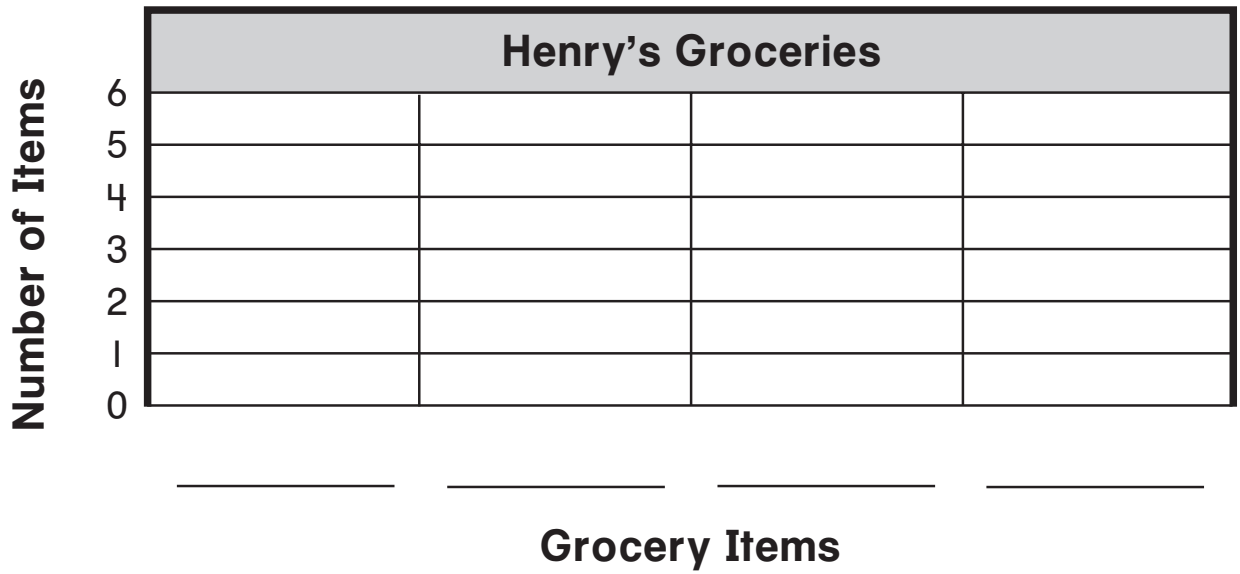
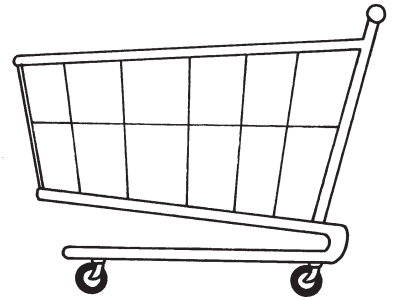

Stretch Your Thinking How many items does Henry buy altogether at the grocery store?

_____ items

Missing Keys

Kelly takes 3 surveys.

She forgets to fill in the key!

Help Kelly complete her pictographs by filling in the key.

1.

Number of Books Read	
Name	Tally
Greg	
Drew	
Liz	

Number of Books Read					
Greg					
Drew					
Liz					

Key: Each stands for _____ books.

2.

Number of Snowy Days This Winter	
Month	Tally
December	
January	
February	

Number of Snowy Days This Winter					
December					
January					
February					

Key: Each stands for _____ days.

3.

Favorite Dog	
Dog	Tally
bulldog	
poodle	
collie	

Favorite Dog					
bulldog					
poodle					
collie					

Key: Each stands for _____ votes.



Stretch Your Thinking Which pictograph shows the greatest number of tally marks received? How do you know?

Make a Line Plot

Max's class made a table to record the number of pockets they had in their clothing.

Make a line plot to show their data.

Then circle the mode of the data.

Number of Pockets in Our Clothing	
Number of Pockets	Number of Children
one	2
two	3
four	2
five	6
seven	3
eight	1

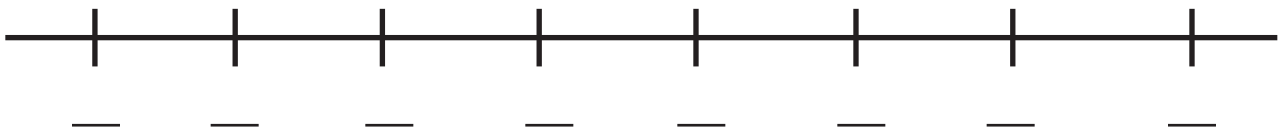

Stretch Your Thinking What is the range of the data? Explain.

Make a Town

Think of 3 places at your school.

Name them and mark them on the grid below.

Describe how to get to each place.

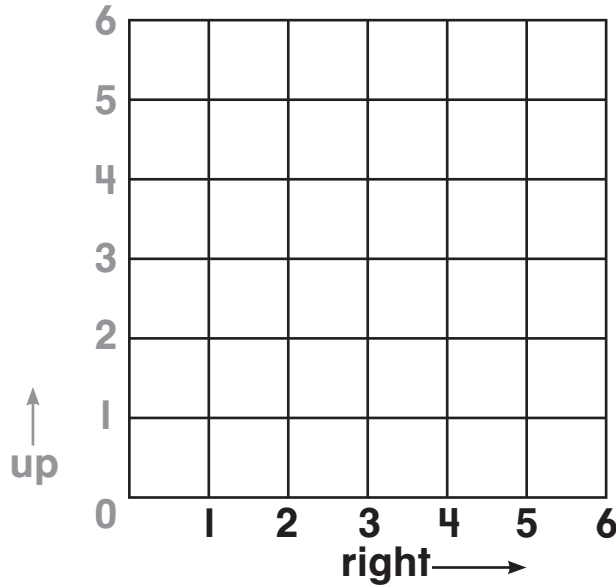

1. Start at 0. Go right _____. Go up _____.

You are at the _____.

2. Start at 0. Go right _____. Go up _____.

You are at the _____.

3. Start at 0. Go right _____. Go up _____.

You are at the _____.



Stretch Your Thinking Choose two places on your grid and tell how to get from one place to the other.

Start at the _____.

Go _____. Go _____.

You are now at the _____.

Color the Spinners

Read the clues below.

Decide which spinner each clue tells about.

Color that spinner to match.

1. This spinner has more than 3 sections and green is an impossible outcome.
2. This spinner has more than 4 sections and green is a certain outcome.
3. The outcomes for this spinner are yellow, blue, red, and orange.
4. This spinner has fewer than 3 sections and blue is a certain outcome.
5. This spinner has 2 sections and blue is an impossible outcome.
6. This spinner has 3 sections and red is a certain outcome.
7. The outcomes for this spinner are yellow and green.

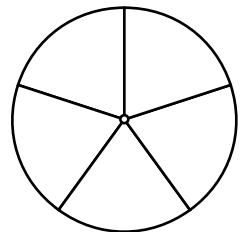
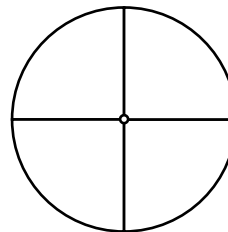
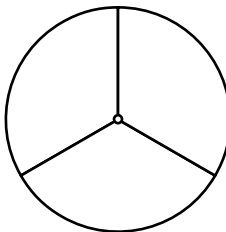
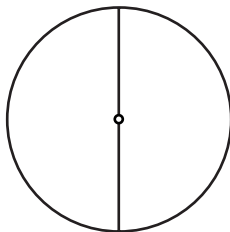
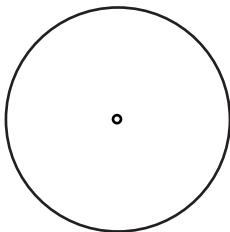

Stretch Your Thinking Is spinning **A** on the spinner certain, impossible, or neither? Explain.

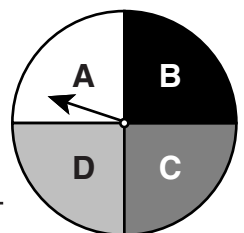

Color the Cubes

Draw cubes in each bag to match the statement.
Use 2 different colors. Then write another true
statement about the cubes in the bag.

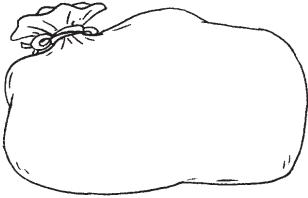

1. It is more likely that a red cube will be pulled.

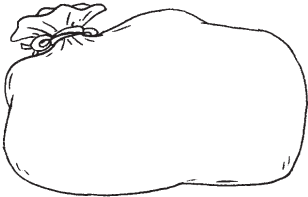

2. It is less likely that a yellow cube will be pulled.

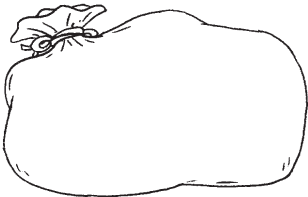

3. It is more likely that a green cube will be pulled.

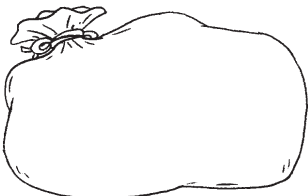

4. It is less likely that a blue cube will be pulled.



Stretch Your Thinking Look at the cubes you drew
in Exercise 4. How many more blue cubes do you need to
add to the bag to make the statement false? Explain.

Missing Spins

1. Jack and Mark each spin the pointer 10 times. Jack spins **F** 5 times and **H** 2 times. Mark spins **F** 3 times and **H** 6 times. Does Jack or Mark spin **G** more often?

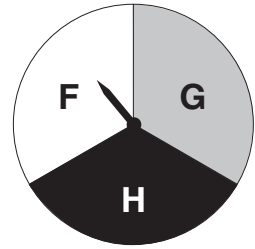

2. Sam and Alex each spin the pointer 12 times. Sam spins **Q** 5 times and **S** 3 times. Alex spins **Q** 4 times and **S** 5 times. Does Sam or Alex spin **R** more often?

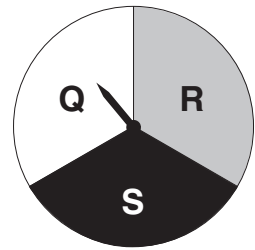

3. Liz and Ann each spin the pointer 15 times. Liz spins **J** 4 times and **M** 5 times. Ann spins **J** 1 time and **M** 6 times. They each spin **K** and **L** an equal number of times. Does Liz or Ann spin **K** more often?

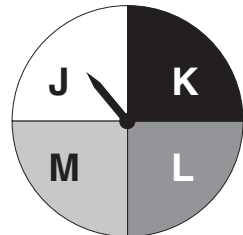

Explain how you solved Exercise 3.

Creative Spinners

Read the clues that tell about each spinner.
Then complete the spinner to match.

1. The outcomes for this spinner are equally likely.

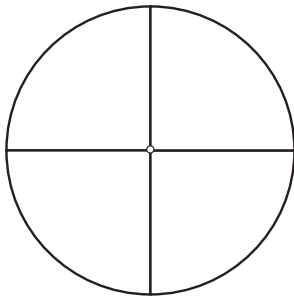

2. The outcomes for this spinner are not equally likely.

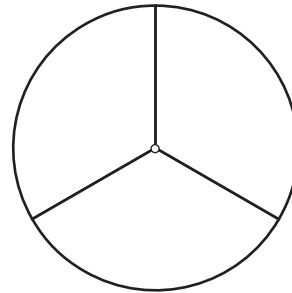

3. The outcomes for this spinner are equally likely.

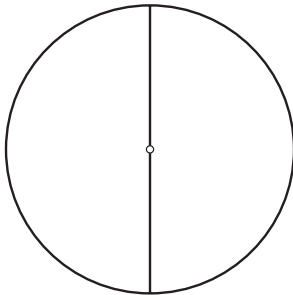

4. The outcomes for this spinner are not equally likely.

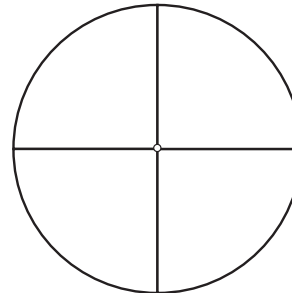

Stretch Your Thinking Look at the spinner in Exercise 3. Will the outcomes always be equally likely when a spinner is divided into two equal sections? Explain why or why not.

Bunches of Flowers

Draw a different bunch of flowers in each vase.
Use coins. Find the total value for each bunch.



daisies
1¢ each



tulips
5¢ each



roses
10¢ each

1.



**total
value:**

2.



**total
value:**

3.



**total
value:**

4.



**total
value:**



Which bunch of flowers costs the most?
How do you know?

What is the Missing Coin?

Draw and label the coins given.

Then draw the missing coin to find the total value.

1. Jim has 2 quarters, 2 pennies, and another coin. He has 77¢ in all. What is the other coin?



missing coin

2. Tasha has 3 dimes, 1 nickel, and another coin. She has 45¢ altogether. What is the other coin?

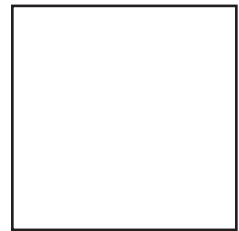

missing coin

3. Carl has 1 half dollar, 1 penny, 2 dimes, and another coin. He has 76¢ in all. What is the other coin?

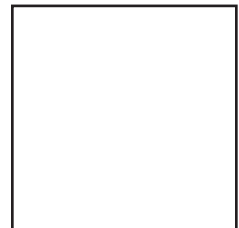

missing coin



How did you find the missing coin in Exercise 3?

Groups of Coins

Find the total value for each group of coins.

1. Gina



_____ total value

2. Ralph



_____ total value

3. Leah









_____ total value



How much more money does Gina need to match Leah's total value? How do you know?

Matching Change

Count the first collection. Find the total value. Complete the second collection to match the total value of the first collection. Draw the missing coins.

<p>1.</p>  <p><u>37¢</u></p>	
<p>2.</p>  <p>_____</p>	
<p>3.</p>  <p>_____</p>	



Stretch Your Thinking What is the least number of coins you can use to show 70¢? Name the coins.

More Than One Way

You can use a list to show ways to make the same amounts using a different number of coins.

Number of Coins	Quarters	Dimes	Nickels	Total Value
4	3	0	1	80¢
8	0	8	0	80¢

Show how to make the same amounts using different numbers of coins.

1.

Number of Coins	Quarters	Dimes	Nickels	Total Value
3				40¢
5				40¢
7				40¢
8				40¢

2.

Number of Coins	Quarters	Dimes	Nickels	Total Value
3				75¢
7				75¢
8				75¢
10				75¢



Can you show a way to make 75¢ using only quarters and dimes? What about 40¢?

Fruit Stand

Write the cost of each fruit. Name the fruit in order from least to greatest cost.

1.



apple



30¢

_____ ,

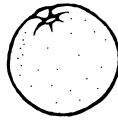

orange



_____ ,



banana



2.



grapes



_____ ,



pear



_____ ,

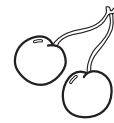

cherries





Make 3 groups of coins. Find the total value of each group. Then put them in order from greatest to least value.

Saving Coins

Use coins to act out the problem.
Draw the coins. Write the total
value. Then answer the question.

1. Lynn saves 1 quarter, 1 dime,
and 4 nickels. She needs 65¢
to buy a postcard. How much
more money does she need?

She needs 10¢ more.

2. Dee saves 1 half dollar, 1 dime,
and 3 nickels. She needs 80¢
to buy a pen. How much more
money does she need?

She needs _____ more.

3. Tim saves 2 quarters, 1 dime,
and 5 pennies. He needs 95¢
to buy a pen. How much more
money does he need?

He needs _____ more.



Stretch Your Thinking Write your own money
problem like the ones above. Have a classmate solve it.

Changing Amounts

Add or subtract to solve.

1. Jade saved 1 quarter, 1 dime and 9 pennies. She gives 12¢ to her sister. How much money does Jade have now?

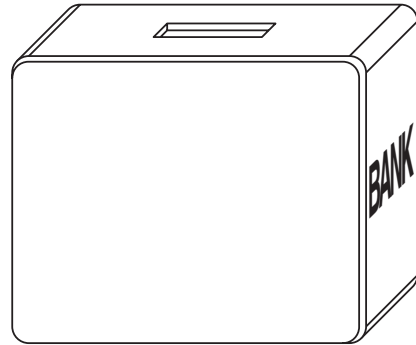

2. Nikki saved 3 dimes, 5 nickels and 5 pennies. She lends 23¢ to her friend. How much money does Nikki have now?

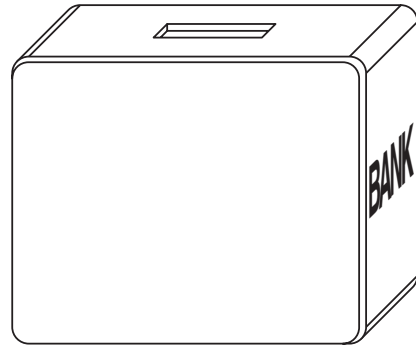

3. Pablo saved 1 quarter, 3 nickels, and 8 pennies. He puts 35¢ more into his bank. How much money does Pablo have now?

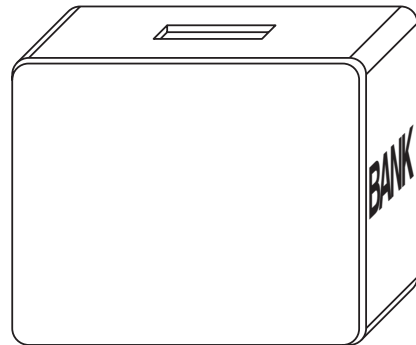

- Julie wants to save 75¢. She has saved 1 quarter and 4 pennies so far. How much more money does she need to save?

On the Menu







Use the menu.

Predict and test to solve.

- Ali has these coins. He wants to spend all his money. He will buy a pretzel and another item. Which other item will he buy?



Snack Shack

	burger	45¢
	juice	42¢
	pretzel	38¢
	milk	33¢
	yogurt	55¢
	apple	27¢

- Sue has these coins. She wants to buy two apples and something else. Which choices does she have?



_____ or _____



Stretch Your Thinking Make a menu. Write your own problem about the menu. Then give it to a classmate to solve.

Make a Dollar

How much more money does each child need to buy the box of crayons?
Draw the coins to solve.



1. Lilly has these coins.



2. Gail has these coins.



3. Tori has these coins.



4. Nick has these coins.



Look at Exercise 4. What other coins could you use to show your answer?

Correct Change

Find the total price. Then count on from the price to make the change.

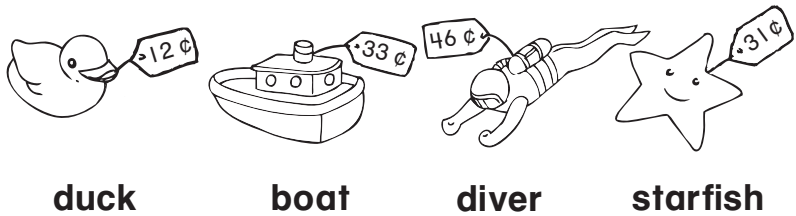

1. Ken has 60¢. He buys a diver and a duck.

Total price: _____.

His change is _____.



_____, _____

2. Lisa has 50¢. She buys a duck and a starfish.

Total price: _____.

Her change is _____.



_____, _____, _____

3. Paul has 80¢. He buys a starfish and a diver.

Total price: _____.

His change is _____.



_____, _____, _____

4. Quan has \$1.00. He buys a boat and a diver.

Total price: _____.

His change is _____.



_____, _____, _____



Julie has \$1.00. She buys a toy frog for 57¢. What coins might she get back in change?

Two Hours at the Park

Jeanette is at the park with her family. They are going to spend 2 hours there. She wants to do 4 different things at the park. Which 4 things can she do in 2 hours? Circle them.

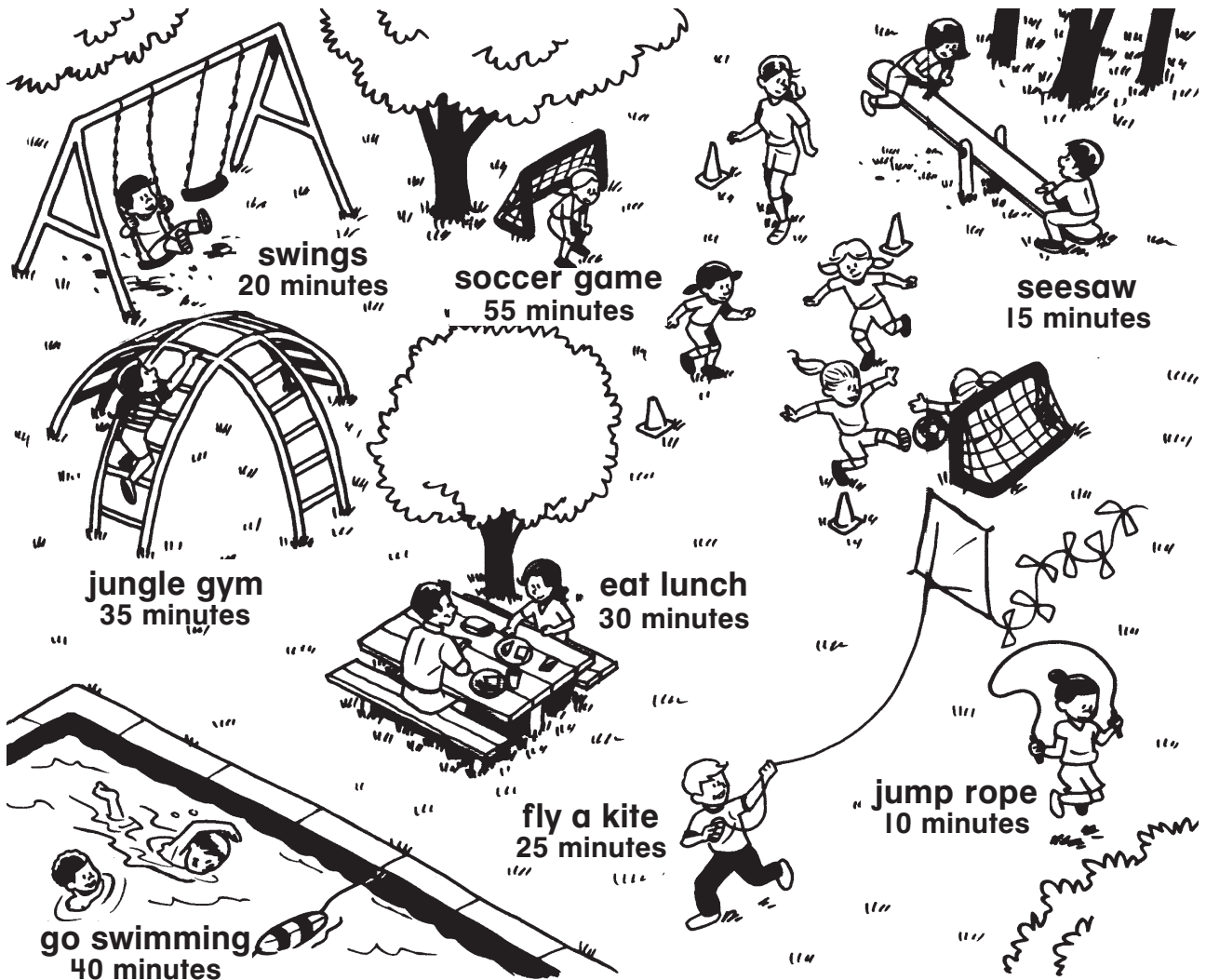

WRITE Math

Jeanette's family decides to stay at the park for 1 more hour. What other things can Jeanette do?

Time Riddle

Write the time below each clock.

I



E

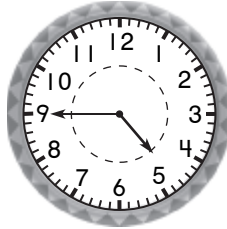

F

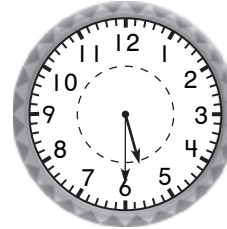

E



T

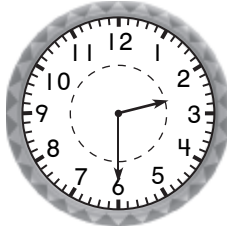

Y

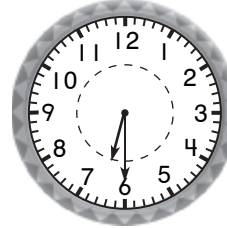

M



L

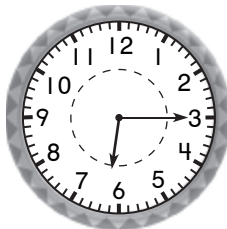

E

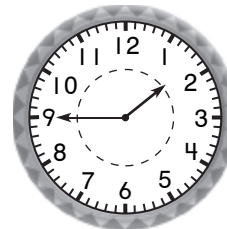



Stretch Your Thinking Put the times in order from earliest to latest. Then write the letter for each time, in order, in the blanks. Solve the riddle.

Why did the boy throw a clock out the window?

TO S _____

Time at the Zoo

Jeremiah and his father go to the zoo.

They get to the monkey house at 10:15.

They spend some time watching each kind of animal.

Draw the clock hands to show what time they leave each part of the zoo.

1. They watch the monkeys for 15 minutes.

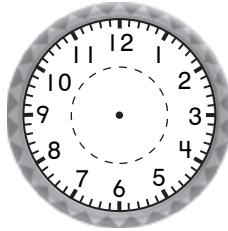

2. They watch the lions for 20 minutes.

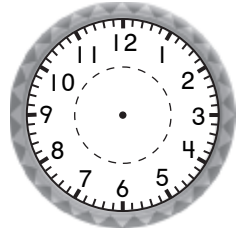

3. They watch the snakes for 5 minutes.

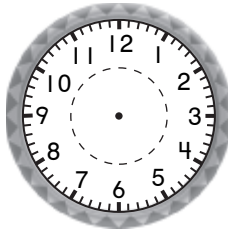

4. They watch the bears for 10 minutes.

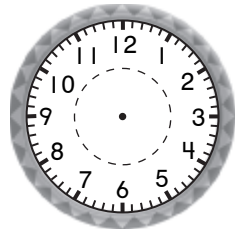

5. They watch the giraffes for 20 minutes.

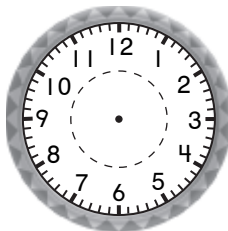

6. They watch the penguins for 25 minutes.

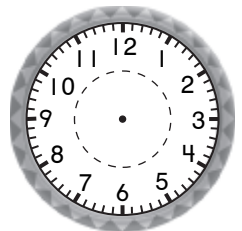

WRITE Math

After they see the penguins, Jeremiah and his father have lunch. They eat for one hour.

Then they leave the zoo. What time do they leave the zoo?

Write the time in two ways.

_____ minutes after _____



School Day

Annabel is making a schedule of her school day.

Fill in the times. Name the activities in order from first to last.

Then draw the hands on the clocks below.

Annabel's School Day Schedule		
science	25 minutes after 12	_____ : _____
lunch	20 minutes before 12	_____ : _____
art	15 minutes after 11	_____ : _____
reading	25 minutes before 10	_____ : _____
recess	50 minutes before 1	_____ : _____
math	30 minutes before 11	_____ : _____

FIRST

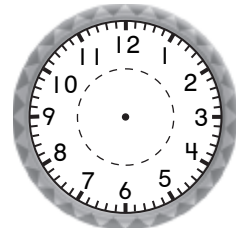
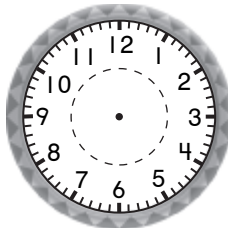
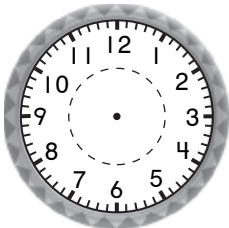

LAST

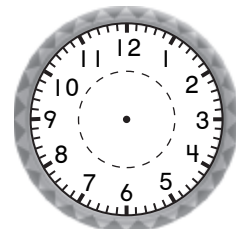
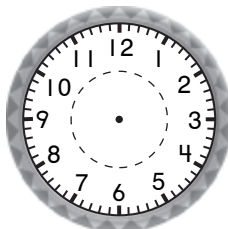
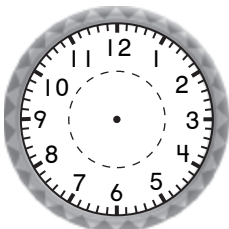



Stretch Your Thinking Make a schedule for your school day. Write the activities in order from first to last. Write the time in two ways.

Time to Estimate

Look at the activities. Make a reasonable estimate for about how long each one might take.

Write your estimate. Use **hours** or **minutes**.

1. take a canoe ride



about _____

2. play a game of ping pong

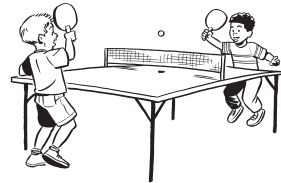

about _____

3. sleep at night



about _____

4. eat some cereal



about _____

5. go on a field trip

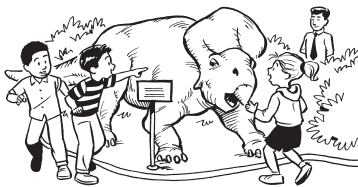

about _____

6. read a poem



about _____

WRITE Math

Explain how you made your estimate for Exercise 6.

Busy from A.M. to P.M.

What do you do in the A.M. hours?

What do you do in the P.M. hours?

Name 5 activities that belong in each column.

Then write a time that each activity might happen.

A.M.	P.M.
_____ _____ : _____	_____ _____ : _____
_____ _____ : _____	_____ _____ : _____
_____ _____ : _____	_____ _____ : _____
_____ _____ : _____	_____ _____ : _____
_____ _____ : _____	_____ _____ : _____



Are there any activities that you do in both the a.m and p.m hours? Explain.

Fair Time

Carla spends her day at the state fair.

It takes her 5 minutes to get from one activity to the next.

Circle the reasonable estimate for how long each activity takes.

Then find the start and finish times.

Activity	Start Time	Length	Finish Time
fun house	10:00 A.M.	15 minutes 3 hours	____ : ____ ____
bobbing for apples	____ : ____ ____	2 hours 20 minutes	____ : ____ ____
hay ride	____ : ____ ____	1 minute 1 hour	____ : ____ ____
lunch	____ : ____ ____	30 minutes 3 hours	____ : ____ ____
petting zoo	____ : ____ ____	45 minutes 4 hours	____ : ____ ____
animal show	____ : ____ ____	50 minutes 5 hours	2:05 P.M.



Does lunch end in an A.M. hour or a P.M. hour?

How do you know?

World Traveler

Alice's Uncle Matt travels all around the world.
Help Alice find out about how much time her
Uncle Matt spends in each city.



Paris: about _____ months

Cairo: _____ weeks

Tokyo: about _____ days

Moscow: about _____ weeks

Johannesburg: about _____ month



Sydney: _____ weeks



Was Alice's Uncle Matt gone for more than 1 year less than 1 year, or exactly 1 year in all? Explain.

Solid Colors

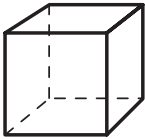
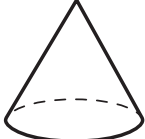
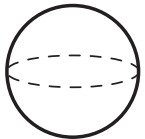
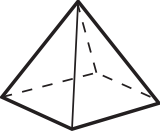
Color each type of solid figure a different color.
Then color the objects below to match the color of the solid it looks like.

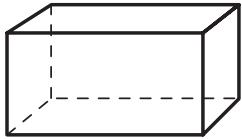
					
cube	cone	sphere	pyramid	cylinder	rectangular prism

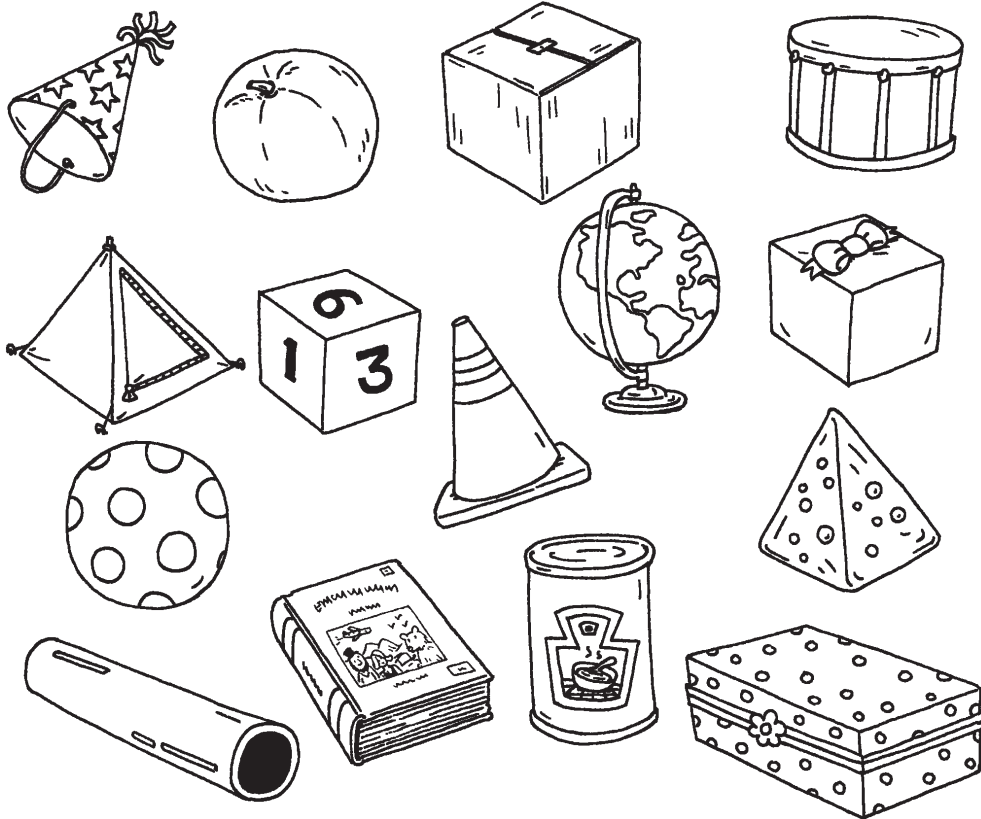

Stretch Your Thinking Find an object that is like a solid figure. Draw and label it.
Then draw and label the solid figure it looks like.

Number Cube Net

This figure can fold into a solid figure.

Number the faces from 1–6.

Then trace, cut, fold, and tape the figure into a cube.

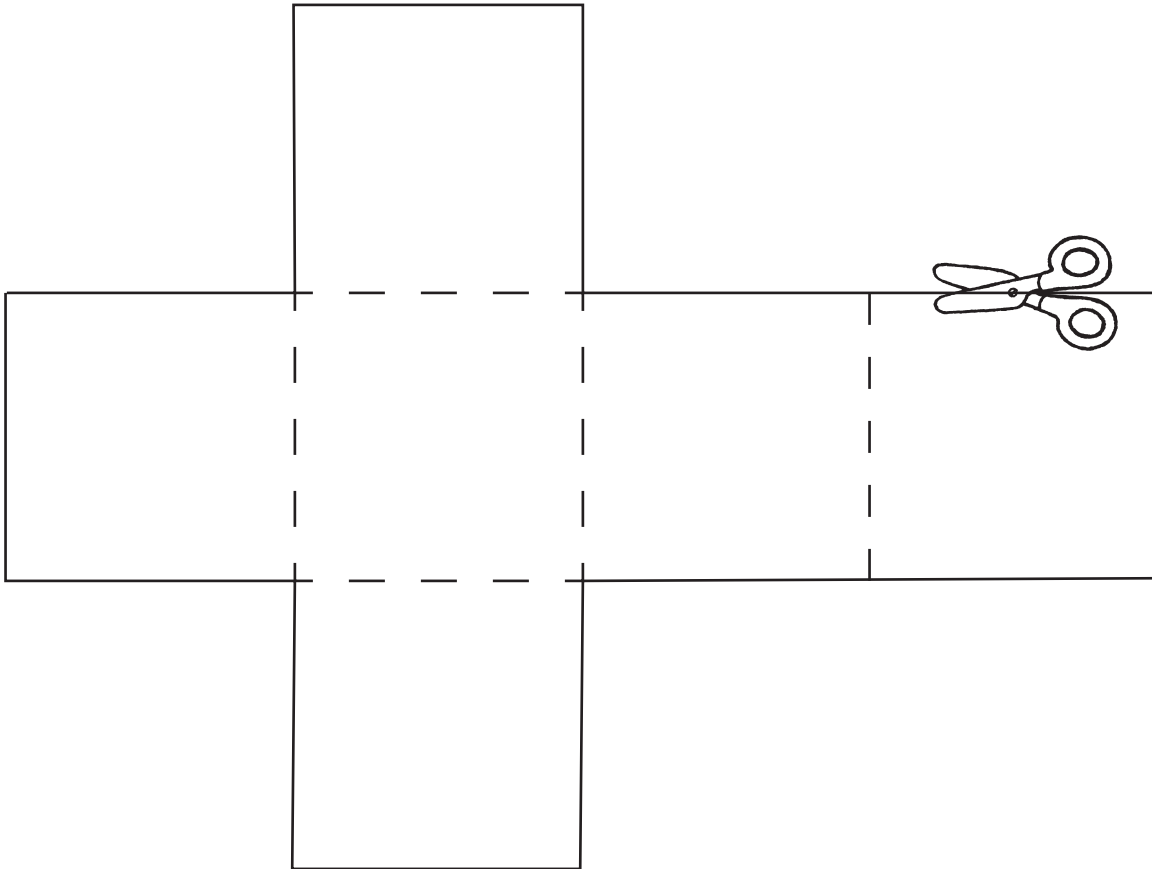

Now you have made a number cube.

With a classmate, write rules for a game.

Use the cube to play the game.



Stretch Your Thinking Draw a figure that will fold into a pyramid.

Solid Figure Puzzle

Use the clues to fill in the puzzle.

Across

- 1. A solid figure which has a curved surface.
- 4. A _____ prism has 6 faces, 12 edges, and 8 vertices.
- 6. the corner where 3 or more edges meet
- 8. A cube has 6 _____.
- 10. a solid figure which has both a flat and a curved surface



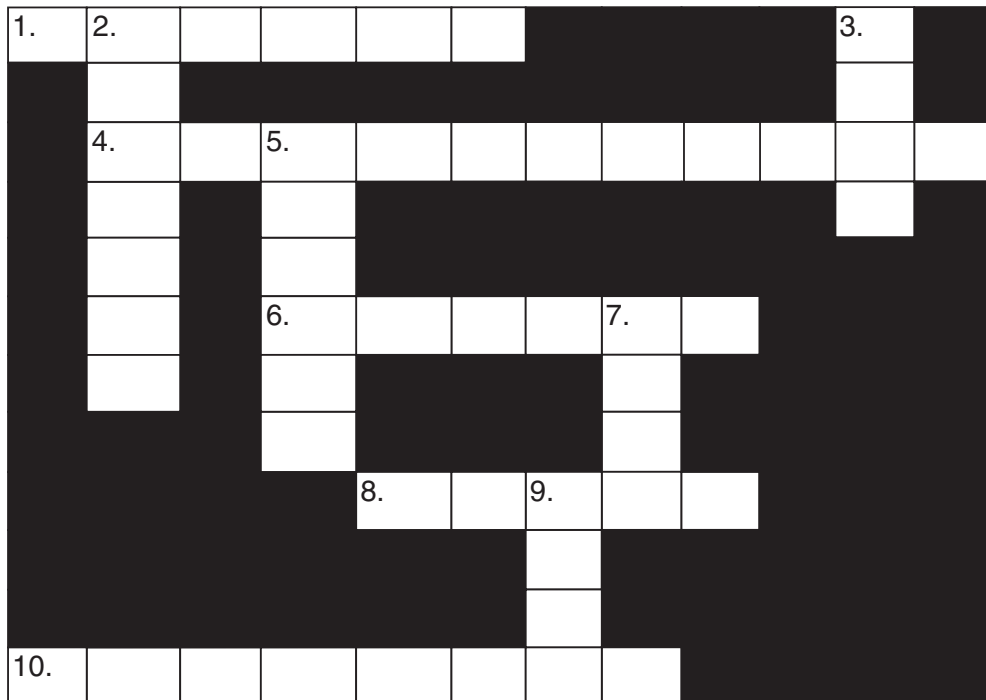

Down

- 2. A solid figure that has 5 faces, 8 edges, and 5 vertices.
- 3. The surface of a cube is _____.
- 5. A sphere has a _____ surface.
- 7. this is formed where two faces meet
- 9. A solid figure whose faces are all the same size and shape.



Solid Figure Riddles

Use solid figures. Draw a line to match the clues to the object they tell about.

- | | | | |
|---|---|---|---|
| 1. I am an object that has the same number of faces, edges, and vertices as a cube. My faces are not all squares. | ● | ● |  |
| 2. I am an object that has a curved surface and a flat surface. I am not a cylinder. | ● | ● |  |
| 3. I am an object that has a curved surface. I am not a cone. | ● | ● |  |
| 4. I am an object that has fewer faces than a rectangular prism. I have 5 vertices. | ● | ● |  |



Stretch Your Thinking Write your own riddle using solid figures. Then have a classmate solve it.

Take It Apart

Draw the plane figures that will make each solid figure.

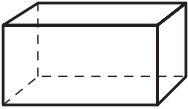
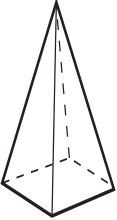
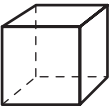
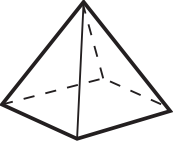
1. 	
2. 	
3. 	
4. 	





Look at the plane figures you drew in Exercises 2 and 4. How are they different? How are they alike?

Making Models



Complete the table to solve.

1. Tasha wants to make models of cylinders and cones. How many circles does she need to make 5 pairs?

Number of Circles on Cylinders and Cones					
number of pairs of cylinders and cones		1			
_____		3			

Tasha needs _____ circles.

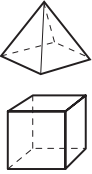
2. Al wants to make models of pyramids and cubes. How many squares does he need to make 4 pairs?

Number of Squares on Pyramids and Cubes				
number of pairs of pyramids and cubes				
_____				

Al needs _____ squares.

Match Plane Figures

Color each plane figure. Use a different color for each type. Find the objects that are like each plane figure. Color each object to match.

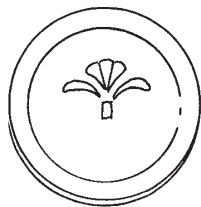
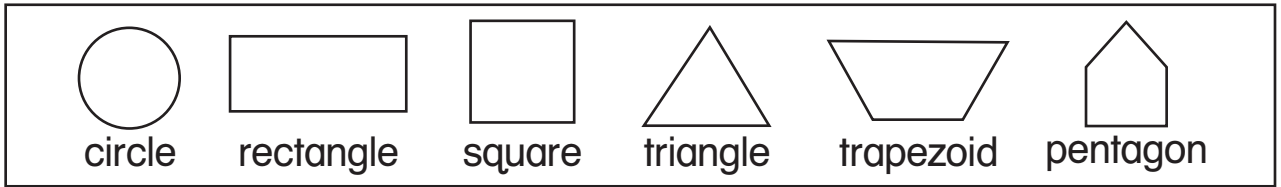

plate

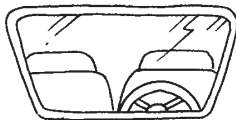

car window

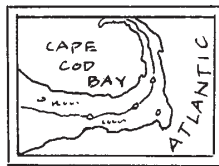

map

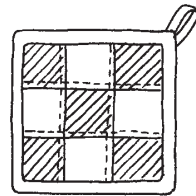

pot holder

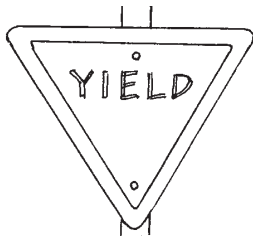

yield sign

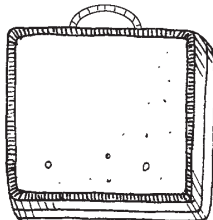

lunch box



school sign

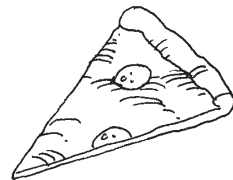

slice of pizza

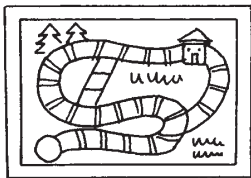

game

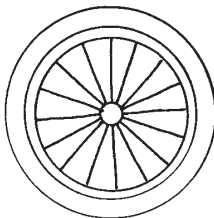

wheel

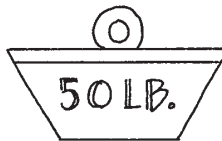

weight



bird house



Stretch Your Thinking Draw a picture that uses all six plane figures above at least once. Ask a classmate to find and name the figures.

Plane Figure Puzzle

Use the clues to fill in the blanks.

Then find the figure in the word puzzle below.

1. A c _ _ _ l e has no sides.
2. A _ q _ _ _ e has 4 sides that are all the same length.
3. A _ e c t _ n g _ _ has 4 vertices.
4. A t _ _ _ _ g l e has fewer than 4 vertices.
5. A v _ _ _ _ x is a point where 2 sides meet.
6. A hexagon has 6 _ _ g e _.
7. A _ r a _ e _ o _ _ has the same number of sides and vertices as a rectangle.

m	n	s	e	f	y	e	c	o	s
a	b	q	u	s	h	m	a	a	q
s	e	u	a	m	x	z	k	e	c
i	g	a	h	c	y	l	a	s	i
d	t	r	i	a	n	g	l	e	r
e	k	e	w	b	i	c	a	g	c
s	u	d	s	r	t	a	e	d	l
r	e	c	t	a	n	g	l	e	e
t	r	a	p	e	z	o	i	d	i
m	e	b	v	e	r	t	e	x	e



What do you notice about the number of sides and vertices on each plane figure?

Two Ways to Top It

Use pattern blocks.

Find two different ways to make each figure.

Draw lines inside the figure to show your solution.

1.



2.

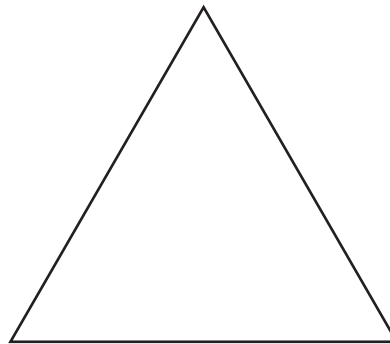
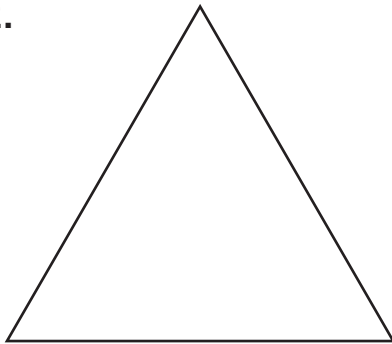

3.

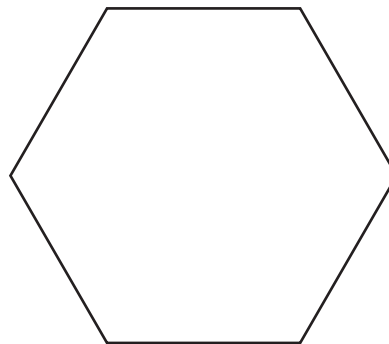
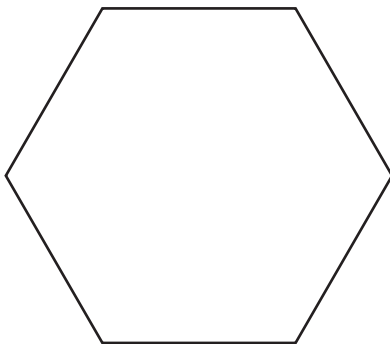

Which two plane figures can you make using 4 squares?

Building Figures

Use pattern blocks. Write the number of smaller figures you can use to make each larger figure.

1.

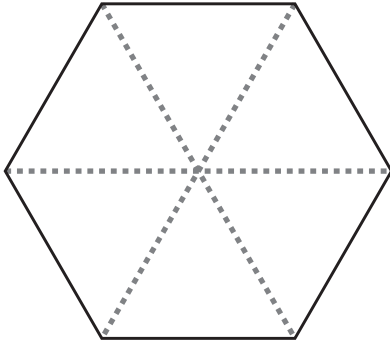

_____ triangles

2.

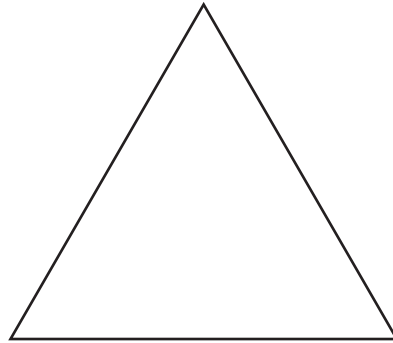

_____ triangles

3.

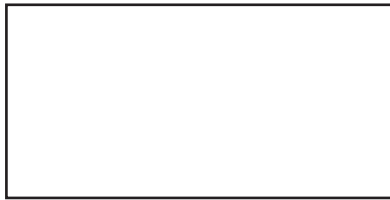

_____ squares

4.



_____ triangles

5.



_____ triangles and
_____ square

6.

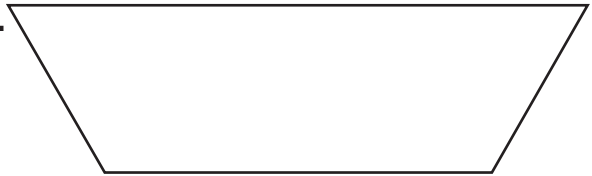

_____ trapezoid and
_____ triangles



Look at Exercise 1. How many ways can you make a hexagon with more than one pattern block that is not a triangle?

Use the Clues

Use logical reasoning to solve.

1. Draw 2 different figures that fit these clues:

I have fewer than 4 vertices.

I have fewer than 4 sides.

2. Draw 3 different figures that fit these clues:

I have 4 vertices.

I have fewer than 6 sides.

I am not a square.

3. Draw 5 different figures that fit these clues:

I have more than 3 vertices.

I have fewer than 8 sides.

I am not a rhombus.



Stretch Your Thinking What clues could you use to describe a square, a trapezoid, and a rhombus?

From Start to Finish

Trace the starting figure. Cut it out.
Follow the directions. Draw the figures.

1. Start with this figure.

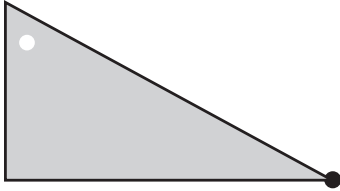

Turn it.

Then flip it to finish.

2. Start with this figure.



Slide it.

Then turn it to finish.

3. Start with this figure.

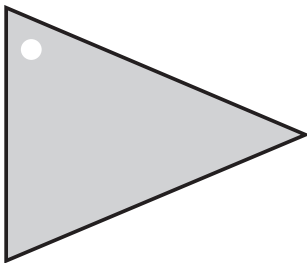

Flip it.

Then slide it to finish.



Look at the figure in Exercise 3. What would the figure look like after 2 more flips? Explain.

Figure Hunt

Shade congruent figures with the same color.

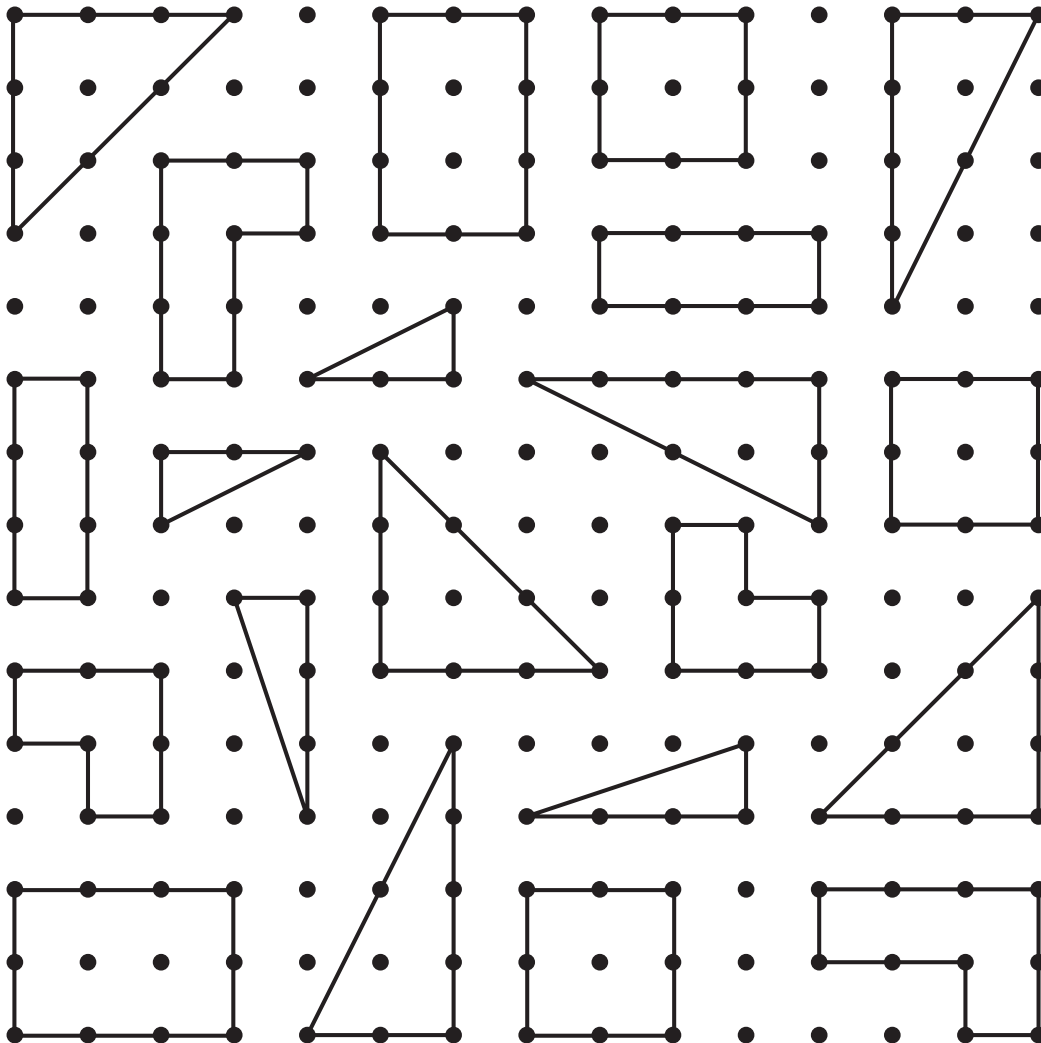

Can you cut any of the figures on this page in half to make two congruent figures?

Explain.

Half and Half

Draw two or more lines of symmetry on each figure.



Stretch Your Thinking Write your first and last name in all capital letters. How many letters in your name have symmetry? Draw a line of symmetry through each of those letters.

Patterned Scarves

Color a different repeating pattern on each scarf.
Then describe the pattern.

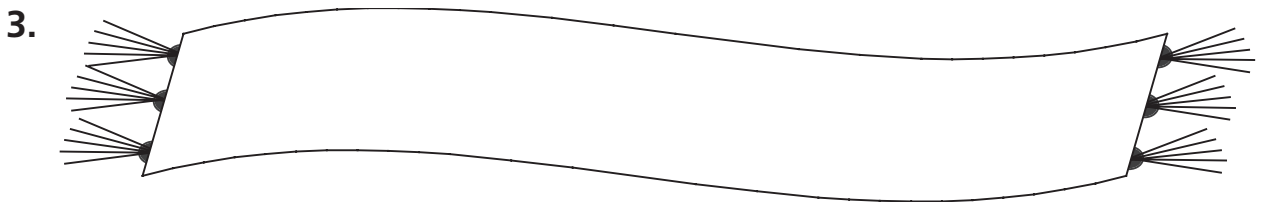
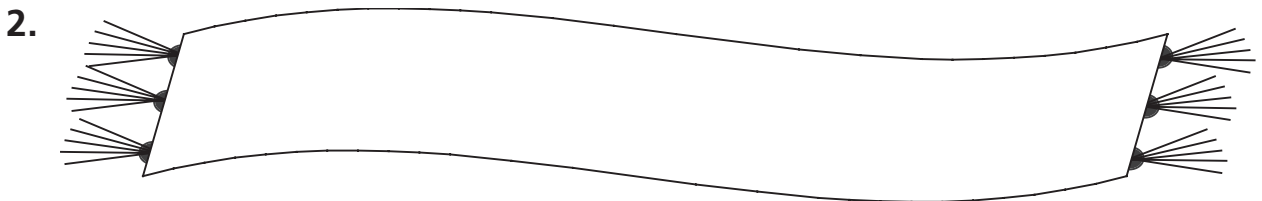
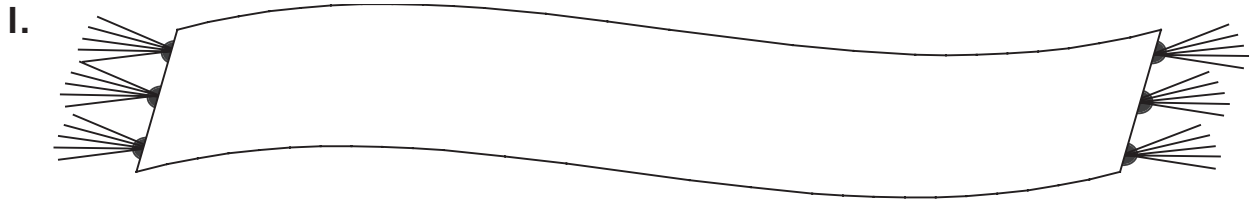



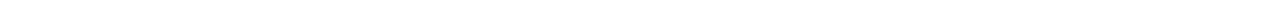













































































Look at Exercise 3. Describe how this is a repeating pattern.



Gridding Patterns

Extend each pattern to fill in the grid.



How did you fill in the bottom right corner of the grid? Explain.

Patterned Pizzas

Select 3 toppings for each pizza. The toppings must form a repeating pattern. Draw each pattern on the pizzas.



pepperoni



tomato



olives



mushrooms



peppers

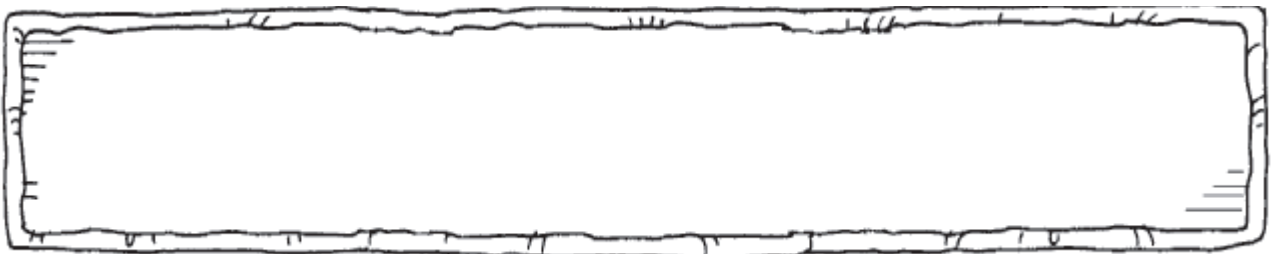
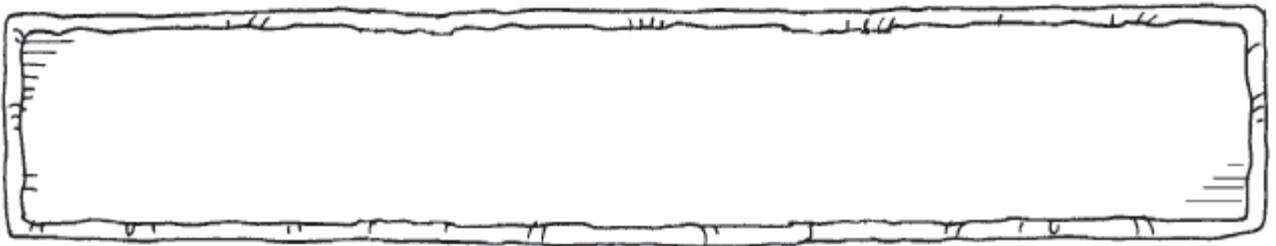
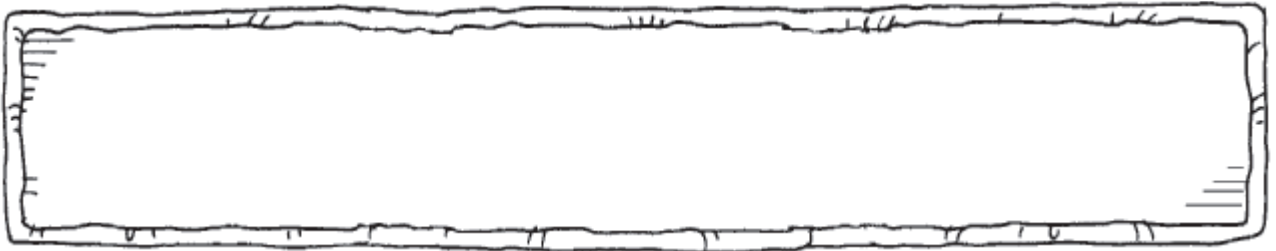

Could you create another pizza with a different pattern? Explain.

Pattern Match

Color to match each pattern unit with the correct pattern.
Then complete the pattern to check your work.

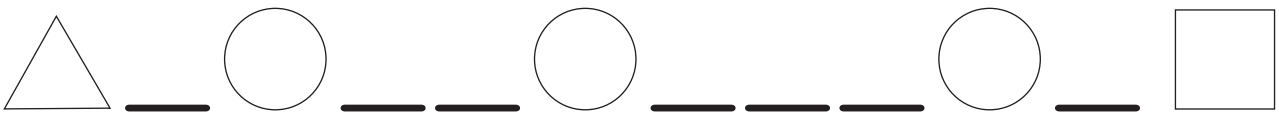
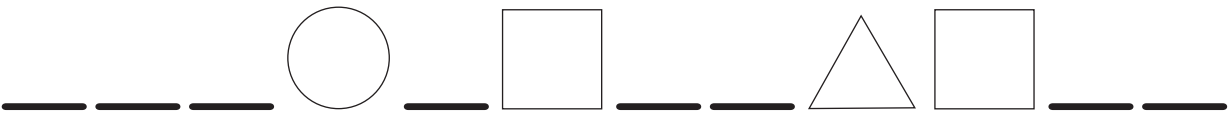
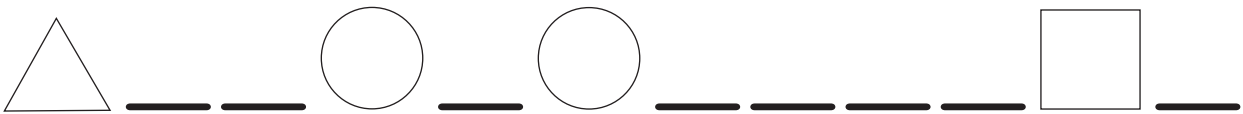
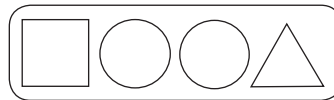
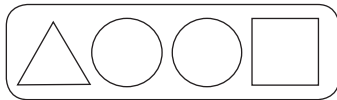
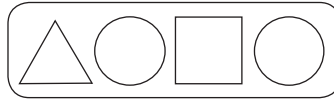
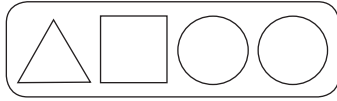

Stretch Your Thinking Use the same 4 figures in the patterns above. Create a different pattern unit. Then repeat the pattern unit to make a new pattern.

How Does the Pattern Grow?

Draw the missing parts of each growing pattern.
Describe the pattern.

1.

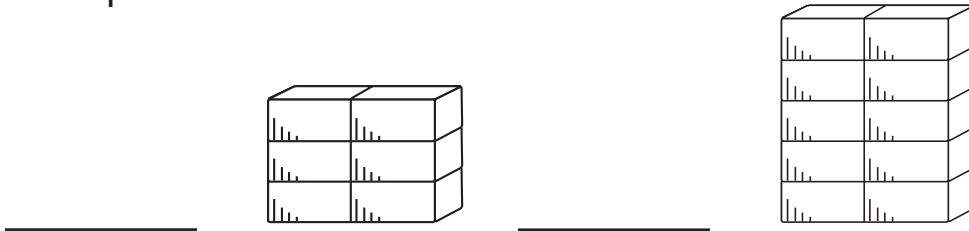

Each stack has _____ more bricks than the last stack.
The bricks are added _____ each time.

2.

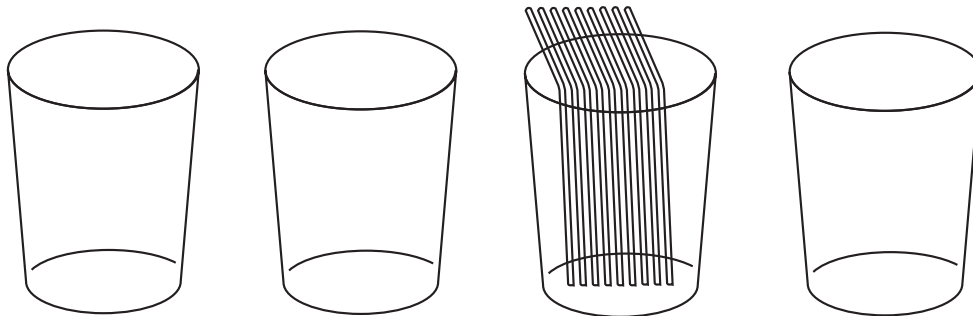

Each cup has 3 more straws than the last cup.
The straws are placed _____.

3.



Each tower has _____ more blocks than the last tower.
The blocks are added _____



Stretch Your Thinking Draw a growing pattern.

Field Day

Simon is in charge of the equipment at field day. He will set up the equipment for each sport in a growing pattern. He needs 4 sets of equipment for each sport. Write the missing number in each growing pattern. Draw each set of sports equipment where it belongs in the growing pattern.

			
1	_____	7	10

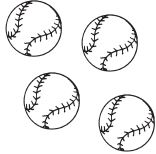
			
2	4	_____	8

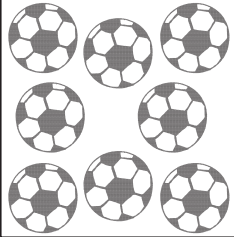
			
_____	6	7	8



Each sport needs one more set. How many of each type will be in the next set?

_____ 

_____ 

_____ 

Coin Collectors

John, Gina, and Sid all start coin collections on Monday.
Write the number of coins they collect. Then write the amount.

1. Sid collects 1 dime each day. How many dimes will he have on Friday?

day	Monday	Tuesday	Wednesday	Thursday	Friday
number of dimes	1				

On Friday, Sid will have _____ dimes.
How much money will Sid have on Friday? _____¢

2. Gina collects 3 nickels each day. How many nickels will she have on Friday?

day	Monday	Tuesday	Wednesday	Thursday	Friday
number of nickels	3				

On Friday, Gina will have _____ nickels.
How much money will Gina have on Friday? _____¢

3. John collects 11 pennies each day. How many pennies will he have on Friday?

day	Monday	Tuesday	Wednesday	Thursday	Friday
number of pennies	11				

On Friday, John will have _____ pennies.
How much money will John have on Friday? _____¢



Who will have the most money on Friday?

Explain your answer.

Compare to Measure

1. Alicia's paintbrush is about 6 beans long. A crayon is about 3 beans long. About how many crayons long is the paintbrush?

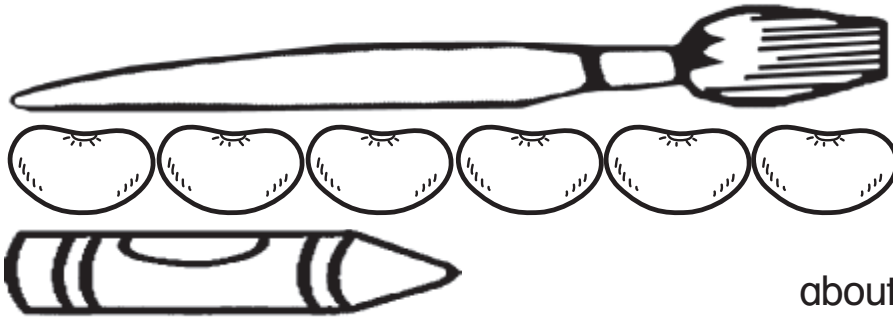

about _____ crayons

2. Bill's watch is about 4 paper clips long. A paper clip is about 2 buttons long. About how many buttons long is the watch?

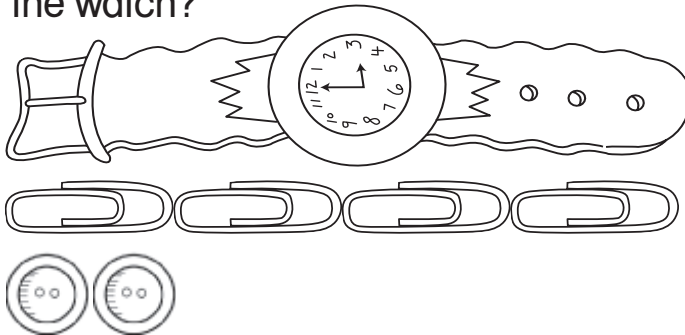

about _____ buttons

3. Maya's necklace is about 9 cubes long. An eraser is about 3 cubes long. About how many erasers long is the necklace?

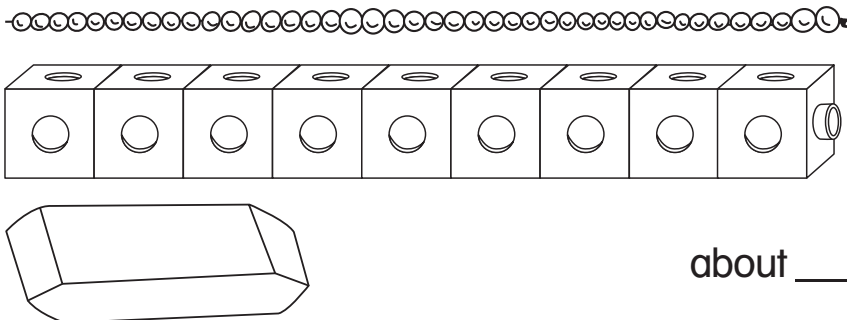

about _____ erasers



The eraser is about 2 beans long. About how many beans long is Maya's necklace? Explain.

Best Estimate

Look around your classroom. Find an object that is about as long as the length given.

1.

10 inches

2.

3 inches

3.

7 inches

4.

1 inch



Explain how you found the object you drew in Exercise 3.

Lengths of Objects

Use the object in the picture to estimate the length of another object.
Draw and label the object below the picture.

1. The spoon is about 4 inches long.
Find an object that is about 3 inches long.

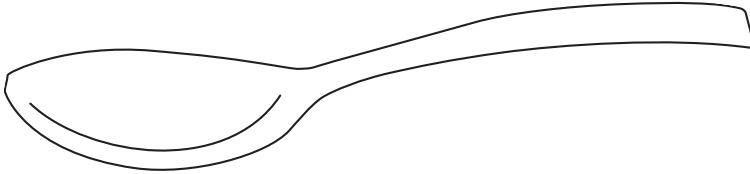

2. The rope is about 2 inches long.
Find an object that is about 7 inches long.





How did you use the pictures to estimate?

Length Riddles

Find a real object to fit the clues. Measure the object. Then draw and label it.

REMEMBER:
 1 foot is equal to 12 inches.
 3 feet is equal to 1 yard.

	Find the object.	Measure it.	Draw and label it.
1.	I am longer than 5 inches but shorter than 1 foot.	_____	_____
2.	I am longer than 1 foot but shorter than 1 yard.	_____	_____
3.	I am longer than 1 yard.	_____	_____



Stretch Your Thinking Write a riddle. Have a partner find an object, measure it, and draw it.

Color the Vegetables

Color the vegetables that are 10 centimeters or longer yellow.
Color the vegetables that are shorter than 10 centimeters green.

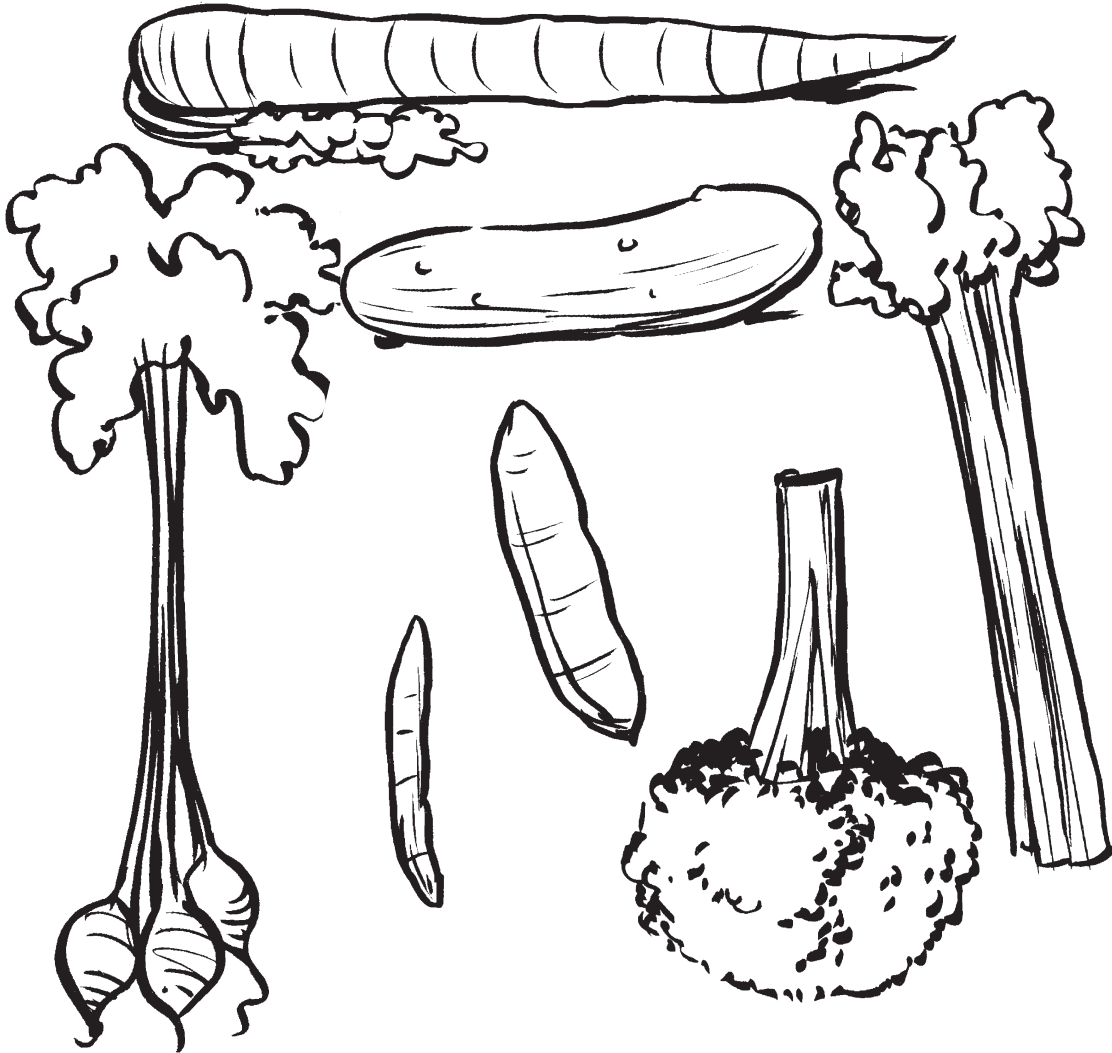

Stretch Your Thinking If you put the same-color vegetables end-to-end, which color would be longer? Explain.

Centi-Meter Fever

Find a real object that fits the clues. Measure the object. Then draw and label it.

REMEMBER:
 A finger is about 1 centimeter across.
 A meter is the same as 100 centimeters.

	Find the object.	Measure it.	Draw and label it.
1.	I am shorter than 10 centimeters.	_____	_____
2.	I am longer than 50 centimeters but shorter than 1 meter.	_____	_____
3.	I am longer than 1 meter.	_____	_____



Stretch Your Thinking How many centimeters long is the object you drew in Exercise 3? Explain.

Draw It

1. Use a ruler. Draw two different figures that each have a perimeter of 20 centimeters.

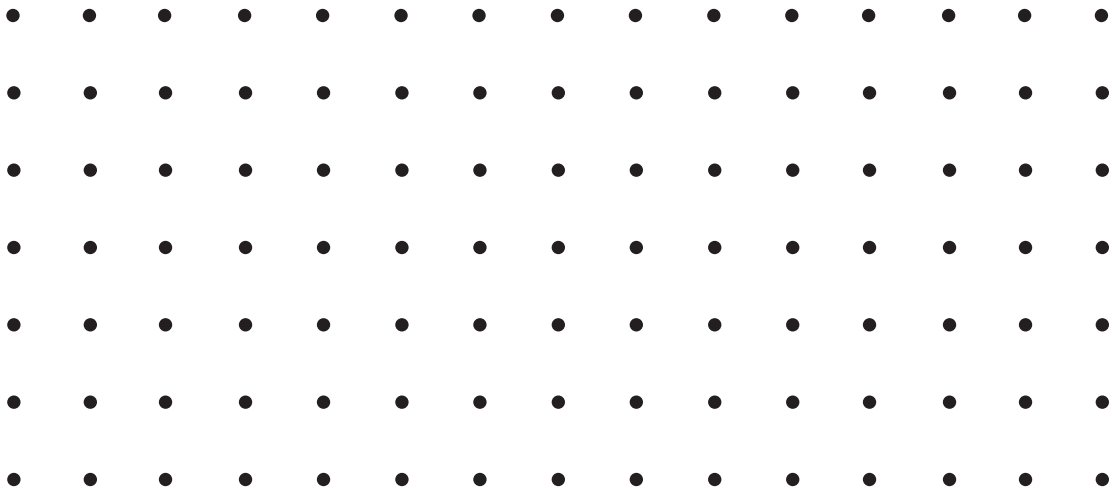

2. Use a ruler. Draw two different figures that each have a perimeter of 12 centimeters.

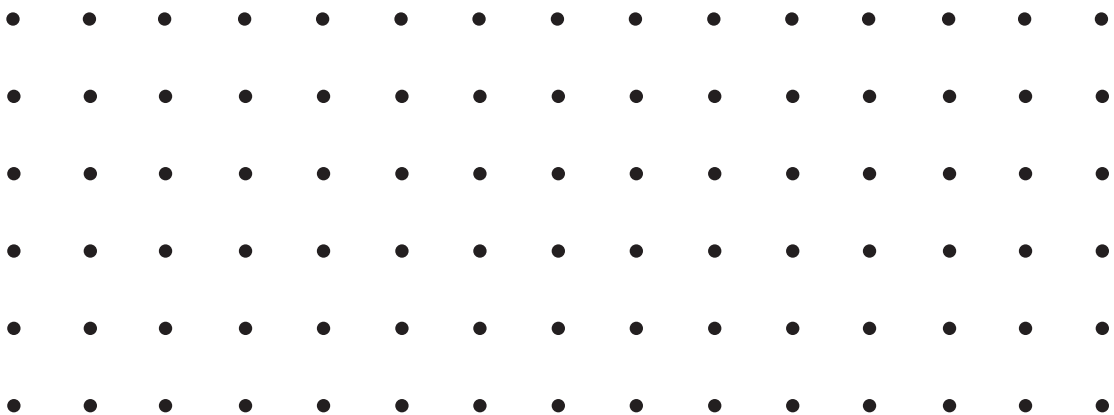

Can a triangle and a square have the same perimeter? Explain.

Square Units

1. Draw two figures. Make the area of one figure 4 square units less than the area of the other figure.

2. Draw two figures. Make the area of one figure 7 square units more than the area of the other figure.





3. Draw two figures. Make the area of one figure 12 square units less than the area of the other figure.

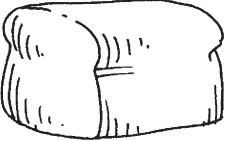
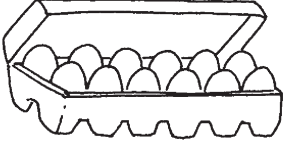

Can different figures have the same area? Explain.

Ounces and Pounds

Laurie goes grocery shopping with her mother. She wants to find the weight of each item in ounces and in pounds. Help Laurie find the weights.

	item	weight in ounces	weight in pounds
1.	bread 	16 ounces	_____ pound
2.	eggs 	_____ ounces	1 pound
3.	apples 	48 ounces	_____ pounds
4.	carrots 	32 ounces	_____ pounds
5.	watermelon 	_____ ounces	4 pounds



How many pounds do the groceries weigh altogether?

_____ pounds

Measuring Mass

Look around your classroom.

Choose two objects that could be measured in grams.

Choose two objects that could be measured in kilograms.

Draw and label the objects. Then measure.

grams	kilograms
<p>1.</p> <p>object: _____</p> <p>mass: about _____ grams</p>	<p>2.</p> <p>object: _____</p> <p>mass: about _____ kilograms</p>
<p>3.</p> <p>object: _____</p> <p>mass: about _____ grams</p>	<p>4.</p> <p>object: _____</p> <p>mass: about _____ kilograms</p>



How did you decide whether the objects should be measured in grams or kilograms? Explain.

Fruit Punch

Julia makes fruit punch for her birthday party.
The recipe calls for different amounts of each juice.
How many cups of each juice does Julia need?

REMEMBER:

2 cups = 1 pint

4 cups = 1 quart

16 cups = 1 gallon

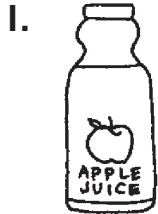

1 quart apple juice = _____ cups

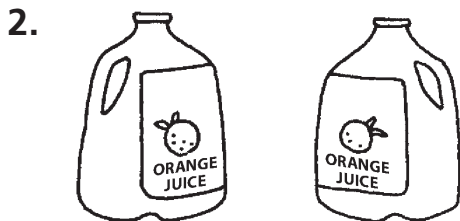

2 gallons orange juice = _____ cups

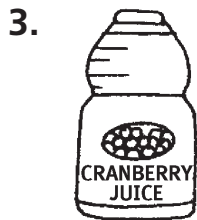

4 pints cranberry juice = _____ cups

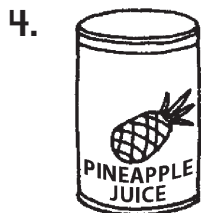

2 quarts pineapple juice = _____ cups

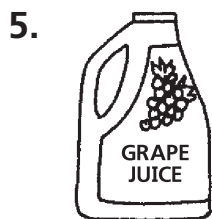

6 pints grape juice = _____ cups



How many cups of juice does Julia need in all?

_____ cups

How many gallons of juice does Julia need in all?

_____ gallons

Changing Temperatures

Wallace has four 70°F glasses of water on the counter.
He does one of these things to each glass to change the temperature:

- puts the glass in the shade** **puts hot water in the glass**
puts ice in the glass **puts the glass in the sun**

Look at the thermometers. Write each temperature.
Then write what Wallace might have done to get each new temperature.

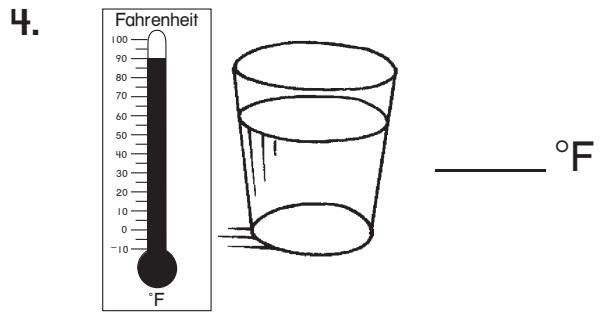
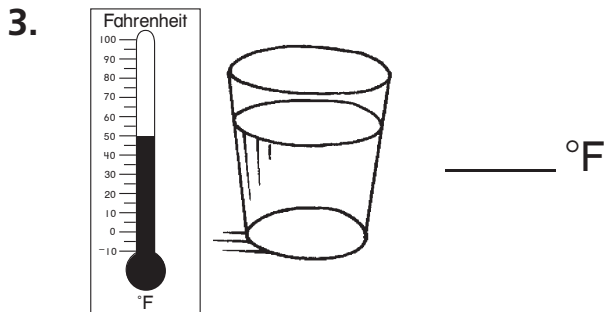
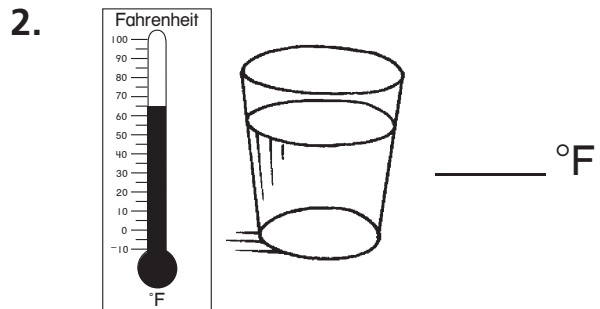
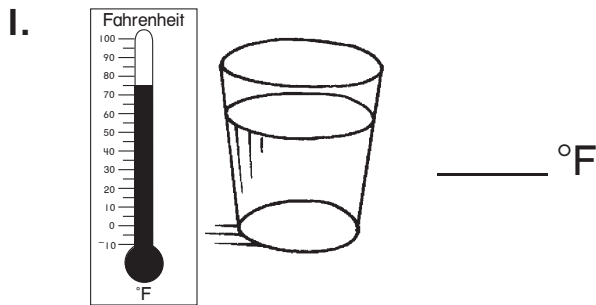

How did you choose which glass Wallace might have put in the sun?

Measurement Search

Find objects that can be measured using each of the tools below. Draw and label the objects. Then measure.

<p>1. cup</p> <p>object: _____</p> <p>measurement: about _____ cups</p>	<p>2. scale</p> <p>object: _____</p> <p>measurement: about _____ grams</p>
<p>3. inch ruler</p> <p>object: _____</p> <p>measurement: about _____ inches</p>	<p>4. °F thermometer</p> <p>object: _____</p> <p>measurement: about _____ °F</p>



Is there more than one tool that could be used to measure a cup of water? Explain.

Make a Quilt

Follow the directions to make a quilt.

1. Color $\frac{3}{25}$ green.

2. Color $\frac{4}{25}$ red.

3. Color $\frac{7}{25}$ yellow.

4. Color $\frac{6}{25}$ blue.



Stretch Your Thinking Use fractions to give more directions about the squares that are left. Then color to follow your directions.

Pizza Party

Kevin invited 3 friends to a pizza party. Draw and color to show how much pizza each boy ate.

1. Kevin ate $\frac{1}{6}$ of a pizza.

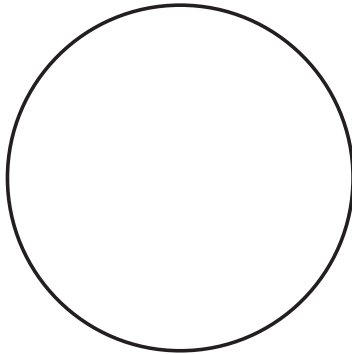

2. Brad ate $\frac{1}{2}$ of a pizza.

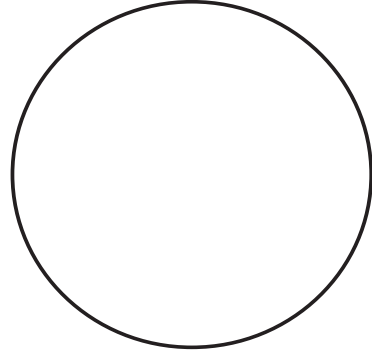

3. Mike ate $\frac{1}{8}$ of a pizza.

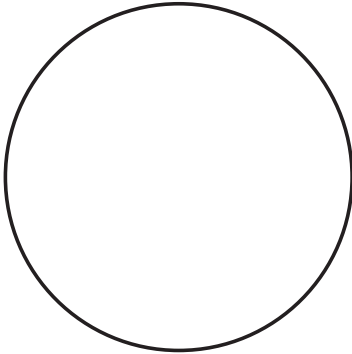

4. Jack ate $\frac{1}{4}$ of a pizza.

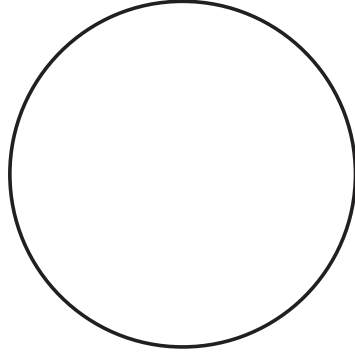

5. List the boys in order from who ate the greatest amount of pizza to who ate the least amount.

_____ greatest

_____ least



How did you decide who ate the most pizza?

Missing Problems

Write a fraction problem for each set of models.

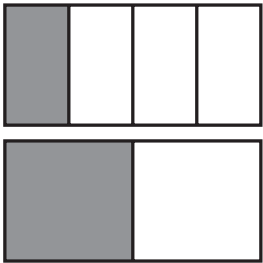
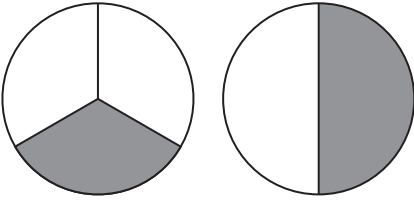
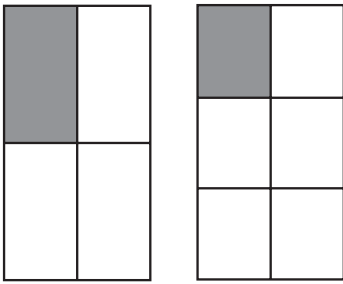
<p>1. _____ _____ _____ _____</p> <p>Answer: _____</p>	
<p>2. _____ _____ _____ _____</p> <p>Answer: _____</p>	
<p>3. _____ _____ _____ _____</p> <p>Answer: _____</p>	



Write your own problem.

Then solve.

Two posters are the same size.

Andy paints $\frac{1}{6}$ of one poster.

Max paints _____ of the other.

Who paints more poster?

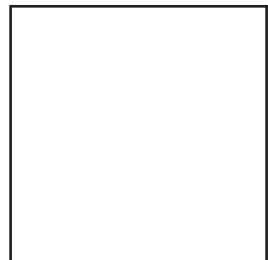

Same Amounts

Color the first figure to show the fraction.
Then color the same area on the second figure.
Write the new fraction.

1.

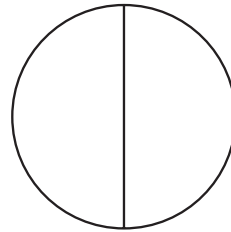
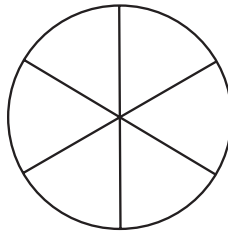
 $\frac{3}{6}$ 

2.

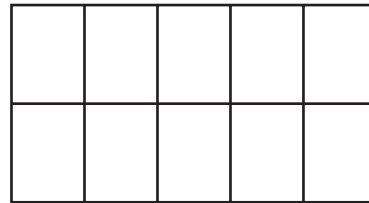
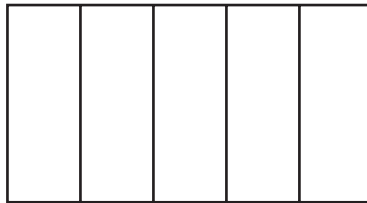
 $\frac{3}{5}$ 

3.

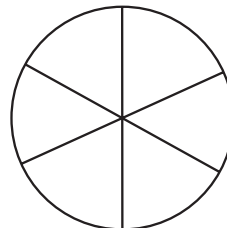
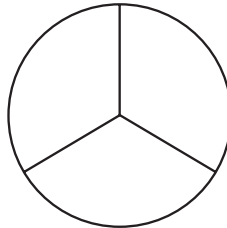
 $\frac{2}{3}$ 

4.

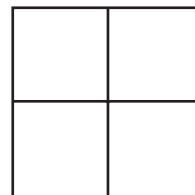
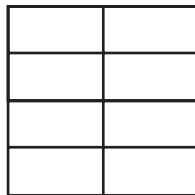
 $\frac{2}{8}$ 



Look at Exercise 3. What fractions name the unshaded area of each figure?

Whole Pizzas

Shade the pizzas to show the fraction.
Then write the number of whole pizzas.

1. $\frac{8}{4} =$ _____ whole pizzas

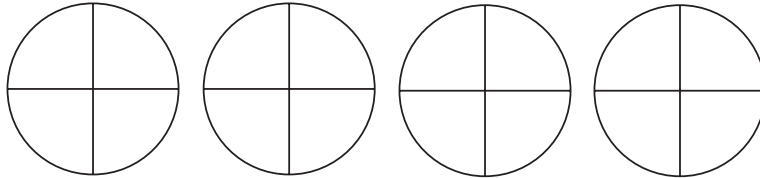

2. $\frac{9}{3} =$ _____ whole pizzas

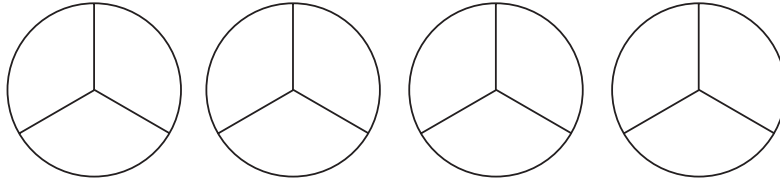

3. $\frac{16}{4} =$ _____ whole pizzas

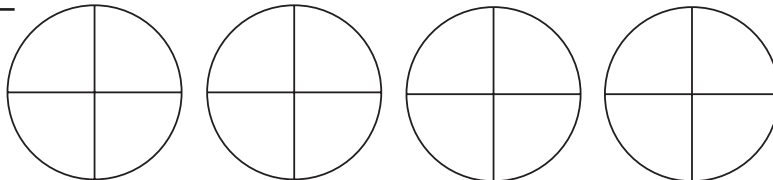

4. $\frac{18}{6} =$ _____ whole pizzas

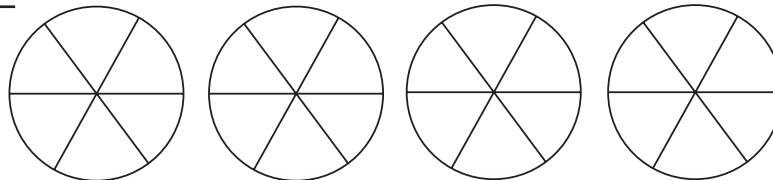

Five pizzas are each cut into 4 equal slices.
What is the fraction for all of the pizza? Explain.

Three Different Parts

Look at the groups.
Write the fraction for each part.

1.

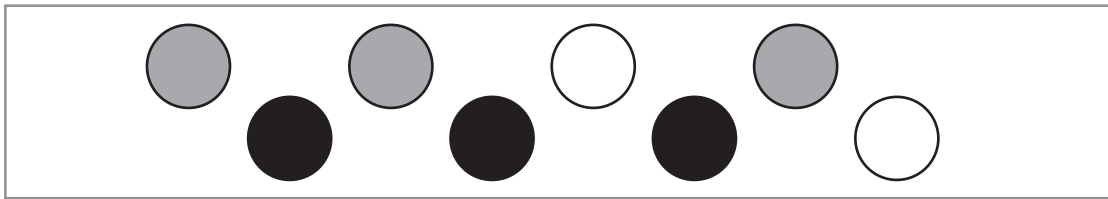

are gray

are black

are white

2.

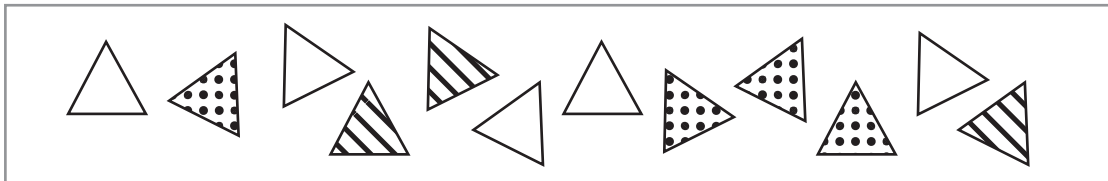

are striped

are spotted

are white

3.



are gray

are striped

are black



Look at the figures in Exercise 3.

Are the black figures **more than**, **less than**, or **equal to** half of the group? Explain.

Greatest and Least

In each row, shade the box that shows the greatest number. Draw an **X** through the box that shows the least number.

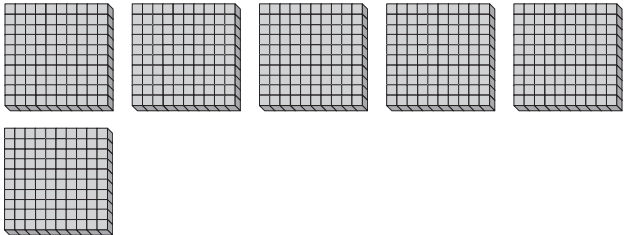
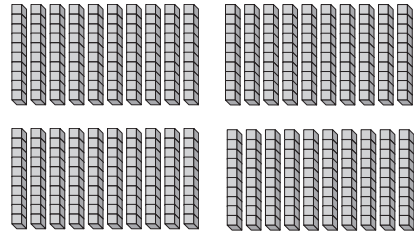
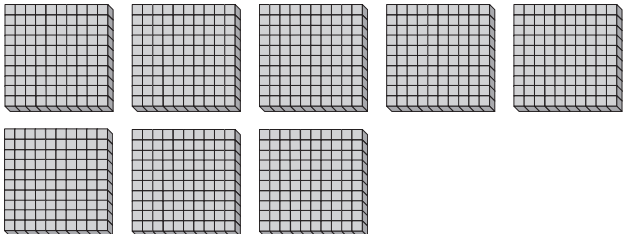
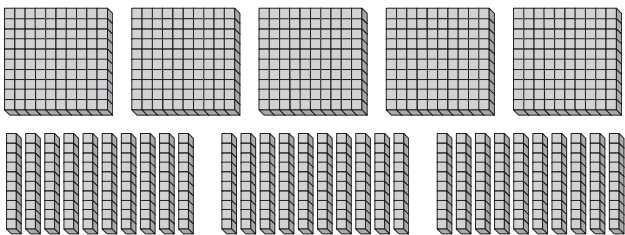
<p>1.</p> 	<p>40 tens</p>	<p>7 hundreds</p>
<p>2.</p> 	<p>80 tens</p>	<p>5 hundreds</p>
<p>3.</p> 	<p>20 tens</p>	<p>3 hundreds</p>
<p>4.</p> 	<p>90 tens</p>	<p>6 hundreds</p>



Stretch Your Thinking Write a problem like those on this page. Ask a classmate to solve.

--	--	--

Showing Numbers

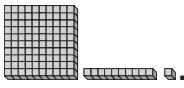
Tommie has some .

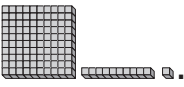
Circle the numbers he can show with his .

Draw an **X** through the numbers he cannot show.

1.

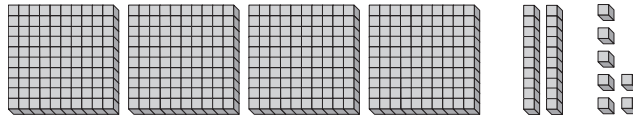

315

227

506

2.

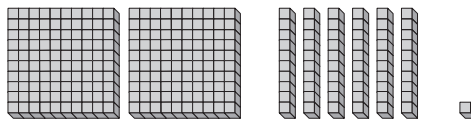

635

118

240

3.

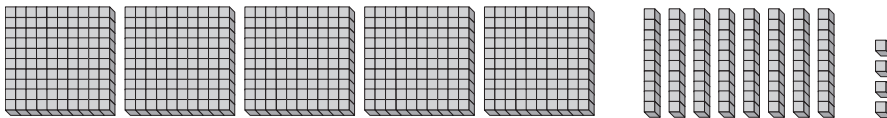

232

599

413

4.

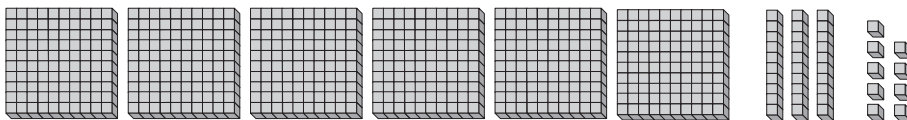

348

708

614

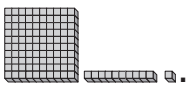

Craig has some .

He can use them to show 427 and 381, but not 576.

Draw the  he might have.

Value Clues

Some friends use the digits 6, 5, and 4 to make numbers. They each use all three digits in their numbers. Use the clues. Write the numbers.

1. JUDITH

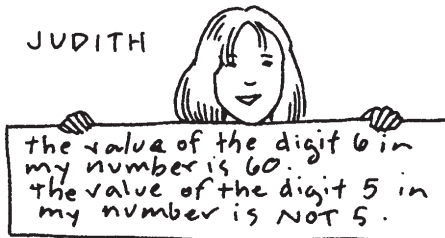

The value of the digit 6 in my number is 60.

The value of the digit 5 in my number is not 5.

My number is _____.

2. RUSTY

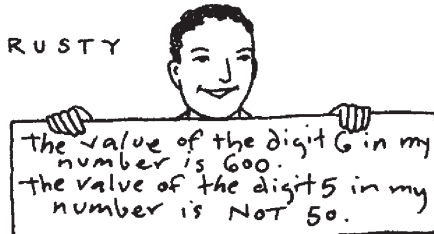

The value of the digit 6 in my number is 600.

The value of the digit 5 in my number is not 50.

My number is _____.

3. SEEMA

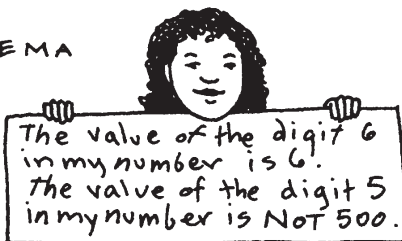

The value of the digit 6 in my number is 6.

The value of the digit 5 in my number is not 500.

My number is _____.

4. ZAK

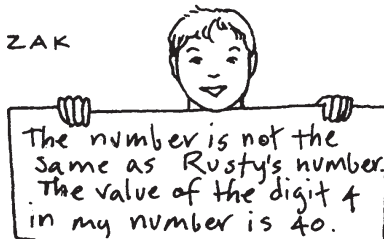

My number is not the same as Rusty's number.

The value of the digit 4 in my number is 40.

My number is _____.



Stretch Your Thinking Write a number that none of the children made. Use the same digits. Then write clues for your number.

Cross-Number Puzzle

Write the missing numbers so the sentences are true.
Read from left to right and from top to bottom.

		70	+		+	3	=	473		
		+		+						
	+	5	+	90	=	295				
+		+		+					+	
3		300	+		+	60	=		9	
+		=		=		+			+	
10		375		497		1			500	
=						+		+	=	
				30	+		+	9	=	539
						=		+		
	+	500	+	60	+			70		
								=		
		100	+		+	9	=	179		



Choose one of the numbers you wrote.

Explain how you found it.

Find the Ways

Circle ways that show the number.

Cross out ways that do not show the number.

1. 753

7 hundreds 5 tens 13 ones

6 hundreds 15 tens 3 ones

6 hundreds 14 tens 13 ones

2. 240

2 hundreds 2 tens 20 ones

1 hundred 14 tens 10 ones

1 hundred 10 tens 40 ones

3. 631

5 hundreds 13 tens 1 one

4 hundreds 23 tens 1 one

6 hundreds 3 tens 11 ones

4. 800

7 hundreds 1 ten 10 ones

7 hundreds 10 tens 0 ones

7 hundreds 9 tens 10 ones

5. 452

3 hundreds 14 tens 12 ones

2 hundreds 50 tens 20 ones

0 hundreds 41 tens 42 ones

6. 333

2 hundreds 13 tens 3 ones

1 hundred 20 tens 33 ones

3 hundreds 13 tens 13 ones



How much is 2 hundreds 20 tens 200 ones?

Explain your answer.

What Coins?

Use bills and coins. Make a model to show each child's money. Then draw the bills and coins.

1. Patrick has \$3.54. He has 3 dollar bills and 6 coins.

--	--

2. Oliver has \$2.15. He has 2 dollar bills and 6 coins.

--	--

3. Luke has \$1.22. He has 1 dollar bill and 5 coins.

--	--

4. Amy has \$2.41. She has 2 dollar bills and 4 coins.



--	--



Stretch Your Thinking Tessa has the same amount of money as Amy. She has 2 dollar bills and 5 coins. What coins could Tessa have?

More or Less

Sofia shows some numbers using   .

Use    to model the number.
Then write the number.

1. Sofia uses 5 blocks to show these numbers.

She uses one .

a number greater than 135

a number less than 110

2. Sofia uses 7 blocks to show these numbers.

She uses one .

a number greater than 600

a number less than 100

3. Sofia uses 9 blocks to show these numbers.

She uses one .

a number greater than 750

a number less than 120



How did you find the numbers you wrote in the first part of Exercise 3? Explain.

Greater, Less, or Equal?

Write each digit once to make numbers that will make the sentences true.

1. 9, 6, 1
 $\underline{1} \underline{6} \underline{9} < 178$

2. 4, 8, 4
 $\underline{\quad} \underline{\quad} \underline{\quad} > 571$

3. 1, 2, 5
 $520 < \underline{\quad} \underline{\quad} \underline{\quad}$

4. 7, 7, 3
 $461 > \underline{\quad} \underline{\quad} \underline{\quad}$

5. 3, 7
 $40 \underline{\quad} > \underline{\quad} 47$

6. 6, 2
 $29 \underline{\quad} = \underline{\quad} 96$

7. 8, 5
 $8 \underline{\quad} 7 < \underline{\quad} 67$

8. 4, 6
 $2 \underline{\quad} 4 > 2 \underline{\quad} 6$

9. 2, 3, 3
 $\underline{\quad} \underline{\quad} 5 < \underline{\quad} 24$

10. 4, 8, 6
 $\underline{\quad} 7 \underline{\quad} < 4 \underline{\quad} 4$



Write a digit to make the sentence true.



$$\underline{\quad} 64 > 890$$

Is there more than one digit you could use? Explain.

The Middle of the Train

Write each number in a train car. Use each number only once. Make sure each set of cars is in the right order.

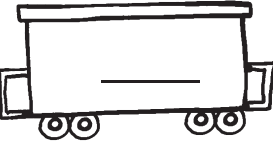
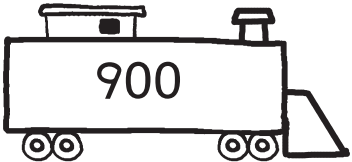
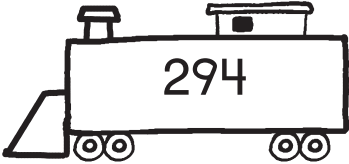
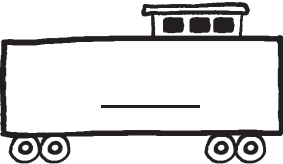

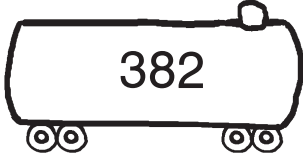
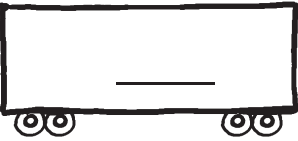
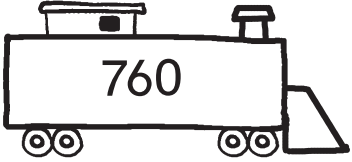
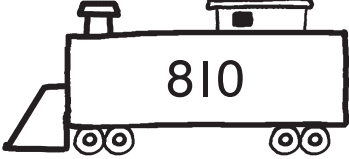
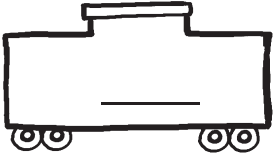
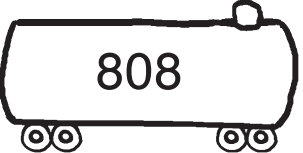
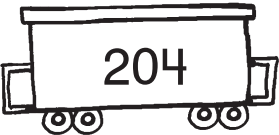
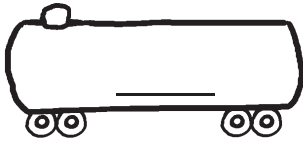
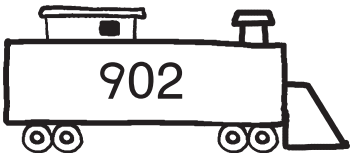
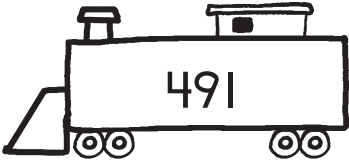
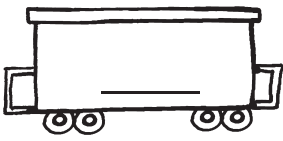
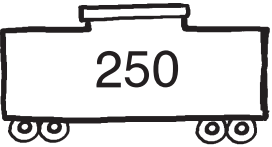
	<		<	
	>		>	
	<		<	
	>		>	
	<		<	
	>		>	



Which number could have been used in more than one car? Explain.

Hundreds of Points

Five friends played a board game.
Use the clues to find how many points
each player scored. Complete the table.

Points Scored	
Player	Points
Nita	
Ellen	
Sal	
Maurice	
James	

1. Nita scored fewer points than Sal.
2. Ellen scored more points than Sal.
but fewer points than James.
3. Nita scored more points than Maurice.
4. James scored 409 points.
5. Maurice scored 398 points.



Name the players in order from
who scored the most points to who scored
the fewest points.

Count by Fives, Count by Tens

Count by fives going across.

Count by tens going down.

Write the missing numbers.

	1.						2.			
								465		
		250	255							
		260		3.						
					905					
	4.						5.			
			785							800



Beth starts at 365 and counts by tens.
Does she say the number 402? Explain?

Hundreds in Your Head

Read the clues. Find the number.

1. A number is 2 hundreds more than 346. What is the number?

546

2. A number is 5 hundreds more than 219. What is the number?

3. A number is 400 more than 153. What is the number?

4. A number is 300 more than 543. What is the number?

5. A number is 6 hundreds more than 181. What is the number?

6. A number is 2 hundreds more than 263. What is the number?

7. 789 is 400 more than a number. What is the number?

8. 812 is 300 more than a number. What is the number?



Stretch Your Thinking Think of a 3-digit number. Write a clue that can be used to find your number.

Scrambled Digits

Use each set of digits to make an addition problem.
Make sure you have to regroup the ones to add.
Then solve.

1. 2 3 4 6 1 2

Hundreds	Tens	Ones
	□	
+		

2. 2 1 3 7 2 4

Hundreds	Tens	Ones
	□	
+		

3. 9 1 3 3 4 4

Hundreds	Tens	Ones
	□	
+		

4. 6 5 3 1 4 2

Hundreds	Tens	Ones
	□	
+		



Look at your numbers in Exercise 4.

How did you make sure you would need to regroup ones?

3-Digit Decisions

Fill in the missing digits.

1.

	Hundreds	Tens	Ones
	<input type="text"/>	1	
	<input type="text"/>	7	5
+	3	<input type="text"/>	<input type="text"/>
—	5	9	4

2.

	Hundreds	Tens	Ones
	1	<input type="text"/>	
	<input type="text"/>	4	<input type="text"/>
+	6	<input type="text"/>	2
—	8	1	5

3.

	Hundreds	Tens	Ones
	<input type="text"/>	<input type="text"/>	
	<input type="text"/>	<input type="text"/>	1
+	5	0	<input type="text"/>
—	9	4	3

4.

	Hundreds	Tens	Ones
	1	<input type="text"/>	
	1	3	<input type="text"/>
+	<input type="text"/>	<input type="text"/>	1
—	5	2	9

5.

	Hundreds	Tens	Ones
	<input type="text"/>	<input type="text"/>	
	8	<input type="text"/>	0
+	<input type="text"/>	2	<input type="text"/>
—	9	9	3

6.

	Hundreds	Tens	Ones
	1	<input type="text"/>	
	<input type="text"/>	9	1
+	2	<input type="text"/>	<input type="text"/>
—	8	5	8

7.

	Hundreds	Tens	Ones
	1	1	
	<input type="text"/>	<input type="text"/>	3
+	1	9	<input type="text"/>
—	8	4	1

8.

	Hundreds	Tens	Ones
	1	1	
	4	<input type="text"/>	1
+	<input type="text"/>	9	<input type="text"/>
—	7	0	0

9.

	Hundreds	Tens	Ones
	<input type="text"/>	<input type="text"/>	
	7	<input type="text"/>	<input type="text"/>
+	1	<input type="text"/>	<input type="text"/>
—	8	0	0



Look at Exercise 9. How did you find the missing numbers? Explain.

What Are the Numbers?

Write what the original addition problem could be for each estimated sum. Give two possibilities.

Round the addends up in one problem and down in the other.

1.

$$\begin{array}{r} \square \longrightarrow 300 \\ + \square \longrightarrow + 200 \\ \hline \square \qquad \qquad 500 \end{array}$$

$$\begin{array}{r} \square \longrightarrow 300 \\ + \square \longrightarrow + 200 \\ \hline \square \qquad \qquad 500 \end{array}$$

2.

$$\begin{array}{r} \square \longrightarrow 500 \\ + \square \longrightarrow + 200 \\ \hline \square \qquad \qquad 700 \end{array}$$

$$\begin{array}{r} \square \longrightarrow 500 \\ + \square \longrightarrow + 200 \\ \hline \square \qquad \qquad 700 \end{array}$$

3.

$$\begin{array}{r} \square \longrightarrow 100 \\ + \square \longrightarrow + 700 \\ \hline \square \qquad \qquad 800 \end{array}$$

$$\begin{array}{r} \square \longrightarrow 100 \\ + \square \longrightarrow + 800 \\ \hline \square \qquad \qquad 900 \end{array}$$



Explain how you found one addend that rounds up to 100 and one addend that rounds down to 100 in Exercise 3.

Use Information

Write a question about each set of information.

Cross out the information you do not need.

Then answer the question.

1. There are 57 turtles sleeping in the mud.
There are are 90 turtles playing in the river.
There are 86 elephants playing in the river.

2. Alexander has 155 blue buttons in a bowl and 211 blue buttons in a box. He has 245 red buttons in the bowl and 196 red buttons in the box.

3. Mrs. Kim read 148 pages of her book on Friday and 263 pages of her book on Saturday. Mr. Holt read 212 pages of his book on Friday and 174 pages of his book on Saturday.



Stretch Your Thinking Write a different question about the information in Exercise 3. Ask a classmate to solve it.

How Many Hundreds?

Count back to find how many hundreds were subtracted.
Write the number of hundreds in the box.

$$1. 836 - \boxed{6} \text{ hundreds} = 236$$

$$2. 452 - \boxed{} \text{ hundreds} = 152$$

$$3. 612 - \boxed{} \text{ hundreds} = 212$$

$$4. 948 - \boxed{} \text{ hundreds} = 248$$

$$5. 324 - \boxed{} \text{ hundreds} = 124$$

$$6. 781 - \boxed{} \text{ hundreds} = 281$$

$$7. 563 - \boxed{} \text{ hundreds} = 263$$



$$8. 819 - \boxed{} \text{ hundreds} = 219$$



Look at Exercise 8. What if the difference was 119? Would the number you write in the box be greater or smaller? Explain.

Disappearing Digits

Write the missing digits.
Show the regrouping if there is any.

Use Workmat 5 and   if you need to.

	Hundreds	Tens	Ones
	<input type="text"/>	7	4
–	7	8	4
	4	2	8
–	3	5	6

	Hundreds	Tens	Ones
	<input type="text"/>	<input type="text"/>	<input type="text"/>
–	4	9	3
	1	5	
–	3	3	6

	Hundreds	Tens	Ones
	<input type="text"/>	<input type="text"/>	<input type="text"/>
–	6	9	2
	3		3
–	3	5	9

	Hundreds	Tens	Ones
	<input type="text"/>	<input type="text"/>	<input type="text"/>
–	3	7	5
	2	4	
–	1	2	9

	Hundreds	Tens	Ones
	<input type="text"/>	<input type="text"/>	<input type="text"/>
–	5	6	3
	4		9
–	1	5	4

	Hundreds	Tens	Ones
	<input type="text"/>	<input type="text"/>	<input type="text"/>
–	9	5	2
	6	2	
–	3	2	4

	Hundreds	Tens	Ones
	<input type="text"/>	<input type="text"/>	<input type="text"/>
–	8	8	4
	5		
–	3	5	9

	Hundreds	Tens	Ones
	<input type="text"/>	<input type="text"/>	<input type="text"/>
–	3	6	1
	1		
–	2	3	7

	Hundreds	Tens	Ones
	<input type="text"/>	<input type="text"/>	<input type="text"/>
–	7	6	5
	6		
–	1	5	0

WRITE Math Look at Exercise 8. How did you find the missing digits? Explain.

Regroup Tens and Hundreds

Use the numbers in the boxes to fill in the subtraction problems. Use each number only once in each problem. Then solve the problems.

1.

6	3	1	6
---	---	---	---

regroup tens only

regroup hundreds only

regroup tens and hundreds

Hundreds	Tens	Ones
□	□	□
8	9	
—		

Hundreds	Tens	Ones
□	□	□
8		9
—		

Hundreds	Tens	Ones
□	□	□
9	8	
—		

2.

9	2	9	3
---	---	---	---

regroup tens only

regroup hundreds only

regroup tens and hundreds

Hundreds	Tens	Ones
□	□	□
	7	5
—		

Hundreds	Tens	Ones
□	□	□
7		5
—		

Hundreds	Tens	Ones
□	□	□
7	5	
—		



Look at the third problem in Exercise 2. Could you have written the digits in different places? Explain.

Keeping Track

You have \$5.50.

Add and subtract to keep track of your money.

- | | |
|--|---|
| 1. You spend \$1.69 on a coloring book. | 2. Your sister gives you 8 dimes. |
| 3. You give your brother 3 quarters. | 4. You get \$2.27 from your father. |
| 5. You find 2 quarters, 4 nickels, and 8 pennies in your jacket. | 6. You spend \$2.47 on a present for your mother. |



What is the difference between the amount you started with and the amount you ended with?

Triple Steps

Solve each triple step problem.
Do one step at a time. Add or subtract to solve.

1. Jay has \$6.90. He buys 2 toy drums. Each drum costs \$1.75. Then he buys a burrito for \$2.25. How much money does Jay have left?



toy drum

Step 1	Step 2	Step 3
Jay has _____ left.		

2. Quinn and Jenna each have \$2.65. They spend \$3.10 on a sandwich to share. How much more money do they need to buy another sandwich?

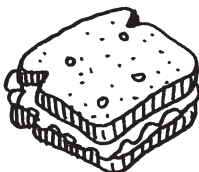

sandwich

Quinn and Jenna need _____ more.		



Stretch Your Thinking Write your own triple step problem. Have a classmate solve.

Estimate to Check

Carson solved these subtraction problems. Estimate to check his answers. If an answer does not make sense, correct Carson's mistake.

1.

$$\begin{array}{r} 295 \longrightarrow \square \\ - 181 \longrightarrow - \square \\ \hline 114 \qquad \square \end{array}$$

2.

$$\begin{array}{r} 405 \longrightarrow \square \\ - 317 \longrightarrow - \square \\ \hline 188 \qquad \square \end{array}$$

3.

$$\begin{array}{r} 789 \longrightarrow \square \\ - 602 \longrightarrow - \square \\ \hline 87 \qquad \square \end{array}$$

4.

$$\begin{array}{r} 892 \longrightarrow \square \\ - 803 \longrightarrow - \square \\ \hline 89 \qquad \square \end{array}$$

5.

$$\begin{array}{r} 687 \longrightarrow \square \\ - 494 \longrightarrow - \square \\ \hline 293 \qquad \square \end{array}$$

6.

$$\begin{array}{r} 794 \longrightarrow \square \\ - 208 \longrightarrow - \square \\ \hline 486 \qquad \square \end{array}$$



How did you solve Exercise 6?

Skip-Counting

Draw equal groups. Skip-count to solve.

1. How many toes are there on 4 feet?

5, 10, 15, 20

There are 20 toes on 4 feet.

2. How many sides are there on 3 hexagons?

There are _____ sides on 3 hexagons.

3. How many wheels are there on 6 cars?

There are _____ wheels on 6 cars.

4. How many vertices are there on 7 triangles?

There are _____ vertices on 7 triangles.



Stretch Your Thinking Write your own problem like the ones on this page. Give it to a classmate to solve.

A Skip-Counting Discovery

Skip-count to find how many in all. Write the multiplication sentence. Tell if the product is **odd** or **even**.

1. Multiply two even numbers.



2 \times 2 = 4



The product is even.



_____ \times _____ = _____



The product is _____.

2. Multiply two odd numbers.

_____ \times _____ = _____



The product is _____.

_____ \times _____ = _____



The product is _____.

3. Multiply an even number and an odd number.

_____ \times _____ = _____

The product is _____.

_____ \times _____ = _____

The product is _____.



When is a product odd? When is it even?

Make a BIG Array

Find each product.

Draw all of the arrays on the grid.

Use a different color for each array.

- | | | |
|-------------------------------------|-------------------------------------|-------------------------------------|
| 1. $1 \times 6 = \underline{6}$ | 2. $3 \times 7 = \underline{\quad}$ | 3. $5 \times 3 = \underline{\quad}$ |
| 4. $3 \times 6 = \underline{\quad}$ | 5. $4 \times 4 = \underline{\quad}$ | 6. $2 \times 7 = \underline{\quad}$ |



What is the product if this entire grid was one array? Explain.

How Many Vertices?

Write a multiplication sentence to show how many vertices there are in each group of figures.

Use the same color to color the groups that have the same number of vertices.

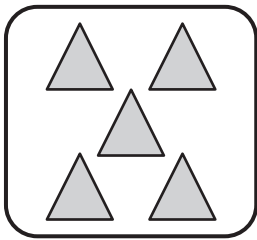

— ○ — ○ —
 ___ vertices

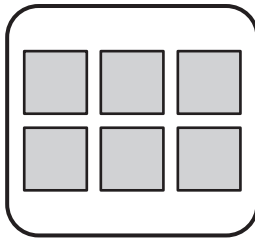

— ○ — ○ —
 ___ vertices

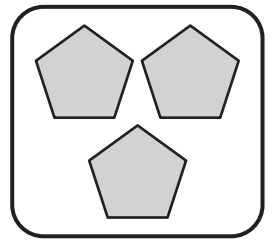

— ○ — ○ —
 ___ vertices

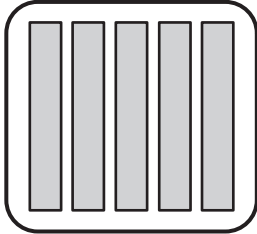

— ○ — ○ —
 ___ vertices

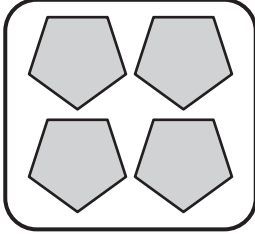

— ○ — ○ —
 ___ vertices

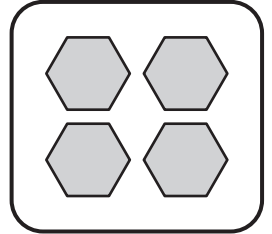

— ○ — ○ —
 ___ vertices



Stretch Your Thinking Which group of figures would have the same number of vertices as 6 triangles? Explain.

Lunch Time

Use the picture to write a multiplication sentence.

1.



___ ○ ___ ○ ___
 ___ bagels

2.



___ ○ ___ ○ ___
 ___ grapes

3.

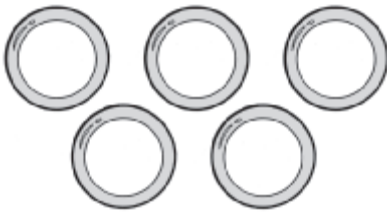

___ ○ ___ ○ ___
 ___ apples

4.



___ ○ ___ ○ ___
 ___ pretzels



Stretch Your Thinking Write a story problem for one of the pictures above. Then write the multiplication sentence for it. Solve.

Write Your Own

Complete the number sentence.
Then complete each word problem.
Draw a picture to go with it.

1. $9 + 2 = \underline{\quad}$

Ayanna has 9 boxes. _____

_____ boxes

2. $9 - 2 = \underline{\quad}$

Sylvie has 9 boxes. _____

3. $9 \times 2 = \underline{\quad}$

Johan has 9 boxes. _____

_____ marbles



Look at Exercise 3.

How did you decide which kind of problem to write?

Are There Any Left?

Use Workmat 6 and ●. Write **yes** or **no**.

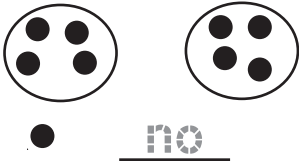
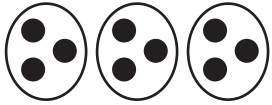
Use this many ●.	Can you make 2 equal groups with none left over?	Can you make 3 equal groups with none left over?
9	 ● <u>no</u>	 <u>yes</u>
10	_____	_____
11	_____	_____
12	_____	_____
13	_____	_____
14	_____	_____
15	_____	_____
16	_____	_____
17	_____	_____



Look at the columns.

Describe a pattern that you see.

A Parade

The second grade classes will march in a parade. Each teacher must divide his or her class into 2 or 3 rows. Each row must have the same number of children. Use ● to help you.

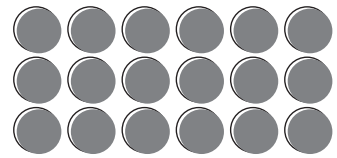

1. Mrs. Jones has 18 children.

3 rows of 6 children

2. Mrs. Kelly has 14 children.

_____ rows of _____ children

3. Mr. Lennon has 20 children.

_____ rows of _____ children

4. Ms. Ryan has 12 children.

_____ rows of _____ children

5. Ms. Howe has 15 children.

_____ rows of _____ children

6. Mr. Flynn has 21 children.

_____ rows of _____ children



What if the children in Mr. Lennon's class were put into 3 rows, would there be an equal number of children in each row? Explain.

Division Puzzles

Each exercise has four division sentences.

Two go from left to right.

The other two go from top to bottom.

Write the missing numbers. Use the number line to help.



1.

12	÷	6	=	<input type="text"/>
÷	<input type="text"/>	÷		
<input type="text"/>	÷	2	=	<input type="text"/>
=		=		
3		<input type="text"/>		

2.

18	÷	9	=	<input type="text"/>
÷	<input type="text"/>	÷		
<input type="text"/>	÷	<input type="text"/>	=	<input type="text"/>
=		=		
3		3		

3.

16	÷	<input type="text"/>	=	4
÷	<input type="text"/>	÷		
8	÷	2	=	<input type="text"/>
=		=		
<input type="text"/>		<input type="text"/>		

4.

<input type="text"/>	÷	10	=	2
÷	<input type="text"/>	÷		
4	÷	2	=	<input type="text"/>
=		=		
5		<input type="text"/>		



Stretch Your Thinking Look at the problems above.

Write a new problem using the same design. Put 24 in the top left corner. Ask a classmate to solve.